



.....
HAWK 2 Family:
.....

(Wide bus)
.....

ST12400W/WD/WC
.....

.....
Product Manual, Volume 1
.....

.....
HAWK 2 Family:
.....

(Wide bus)
.....

ST12400W/WD/WC
.....

.....
Product Manual, Volume 1
.....



© 1995 Seagate Technology, Inc. All rights reserved
Publication Number: 77767457, Rev. C
March 1995

Seagate®, Seagate Technology® and the Seagate logo are registered trademarks of Seagate Technology, Inc. Hawk™, SeaFAX™, SeaFone™, SeaTDD™ and SeaBOARD™ are trademarks of Seagate Technology, Inc. Other product names are registered trademarks or trademarks of their owners.

Seagate reserves the right to change, without notice, product offerings or specifications. No part of this publication may be reproduced in any form without written permission of Seagate Technology, Inc.

Revision status summary sheet

Revision	Authority	Date	Writer/Eng.	Sheets Affected
A Issue		8/5/94	D. Ashby	v through viii, 1 through 71
B	PLD:84538	01/18/95	D. Ashby	v, viii, 21, 23, 69 and 71
C	PLD:84542	03/17/95	J. Rust/J. Bentley	v, 24, 25, 70, 71.

Notice.

Product Manual 77767457 is Volume 1 of a two Volume document with the SCSI interface information in the Volume 2 SCSI Interface Product Manual, P/N 77738479.

If the SCSI Interface information is needed the Volume 2 Interface Manual should be ordered, P/N 77738479.

Table of contents

1.0	Scope	1
2.0	Applicable standards and reference documentation	2
2.1	Standards	2
2.2	Applicable reference documents	2
3.0	General description	3
4.0	Standards features	5
4.1.	Performance	5
4.1.1	Reliability	5
4.2	Unformatted and formatted capacities	6
4.3	Options (factory installed)	6
4.4	Optional accessories (user installed)	6
4.5	Installation	7
5.0	Performance characteristics	8
5.1	Internal drive characteristics (transparent to user)	8
5.2	SCSI drive Seek, Read and Write performance characteristics (Visible to User)	8
5.2.1	Seek time	8
5.2.2	Format drive command execution time	9
5.2.3	Read data command execution time	9
5.2.4	Write data command execution time	9
5.3	Generalized performance characteristics	10
5.4	Start/stop time	11
5.5	Prefetch/multi segmented cache control	12
5.5.1	Cache operation	12
5.5.2	Prefetch operation	13
5.6	Caching write data	14
5.7	Synchronized spindle operation	14
6.0	Reliability specifications	18
6.1	Error rates	18
6.1.1	Read errors	18
6.1.2	Environmental interference	18
6.1.3	Write errors	19
6.1.4	Seek errors	19

Table of contents

6.2	Reliability and service	19
6.2.1	Mean time between failure	19
6.2.2	Preventive maintenance	19
6.2.3	Service life	19
6.2.4	Service philosophy	20
6.2.5	Installation	20
6.2.6	Service tools	20
6.2.7	Product Warranty	20
7.0	Physical/electrical specifications	21
7.1	AC power requirements	21
7.2	DC power requirements	21
7.2.1	Conducted noise immunity	22
7.2.2	Power sequencing	22
7.2.3	12 V - current profile	22
7.3	Heat/power dissipation	23
7.4	Environmental limits	23
7.4.1	Temperature	24
7.4.2	Relative humidity	26
7.4.3	Effective altitude (sea level ref)	26
7.4.4	Shock and vibration	26
7.4.5	Air cleanliness	28
7.5	Electromagnetic compatibility	28
7.5.1	Electromagnetic susceptibility	28
7.6	Mechanical specifications	29
7.6.1	Drive orientation	29
7.6.2	Cooling	30
7.6.3	Drive mounting	30
8.0	Media characteristics	31
8.1	Media description	31
9.0	Defect and error management	32
9.1	Drive internal defects/errors	32
9.2	SCSI systems error considerations	32
10.0	Option/configuration headers	33
10.1	Drive ID/option select header	33
10.2	Synchronized spindles interface	39
10.2.1	Electrical description	39
10.3	Grounding	40

Table of contents

11.0	Interface requirement	41
11.1	General description	41
11.2	SCSI interface messages supported	42
11.3	SCSI interface commands supported	43
	11.3.1 Inquiry data	45
	11.3.2 Mode sense data	46
11.4	SCSI bus conditions and miscellaneous features supported	49
11.5	Synchronous data transfer	50
	11.5.1 Synchronous data transfer periods supported	50
	11.5.2 REQ/ACK offset	50
11.6	Physical interface	51
	11.6.1 DC cable and connector	52
	11.6.2 Physical characteristics	52
	11.6.3 Connector requirements	53
	11.6.4 Electrical description	60
11.7	Disc drive timing	65
12.0	Options	67
12.1	Front panel	67
12.2	Single unit shipping pack	67
13.0	Accessories	68
13.1	Front panel kit	68
13.2	Installation manual	68
14.0	Seagate Technical Support services	69
	Seagate Peripheral Family	70

1.0 Scope

This specification describes the Seagate Technology, Inc. Hawk 2 family Model ST12400 Wide SCSI bus Disc Drive. This high capacity, high performance member of the Seagate 3.5 inch rigid disc family has a new HDA (Head/Disc Assembly) design having improvements over previous 3.5-inch Seagate models. It has an embedded SCSI controller. Performance information is given in Section 5. The Model Hawk 2 Family (Wide bus) drive interface is defined for functional compatibility to a subset of the Seagate SCSI-2/SCSI-3 Interface Specification 77738479, and the ANSI SCSI-2/SCSI-3 standards. The Model Hawk 2 Family (Wide bus) drives are classified as “Intelligent” peripherals. The Hawk 2 Family (Wide bus) provides Level 2 conformance (highest level) with the ANSI SCSI-1 standard. Details of the Hawk 2 Family (Wide bus) drive SCSI implementation are provided in Section 11 of this specification, (Volume 1) and in the SCSI-2/SCSI-3 Interface Product Manual P/N 77738479 (Vol. 2; Ver. 2).

The Hawk 2 wide family of drives consists of the ST12400W, ST12400WD and ST12400WC drives.

From this point on in this Product Manual the reference to Hawk 2 Family (Wide bus) is referred to as “the drive” (unless reference to individual models are necessary).

The drive printed circuit board is referred to as a PCB.

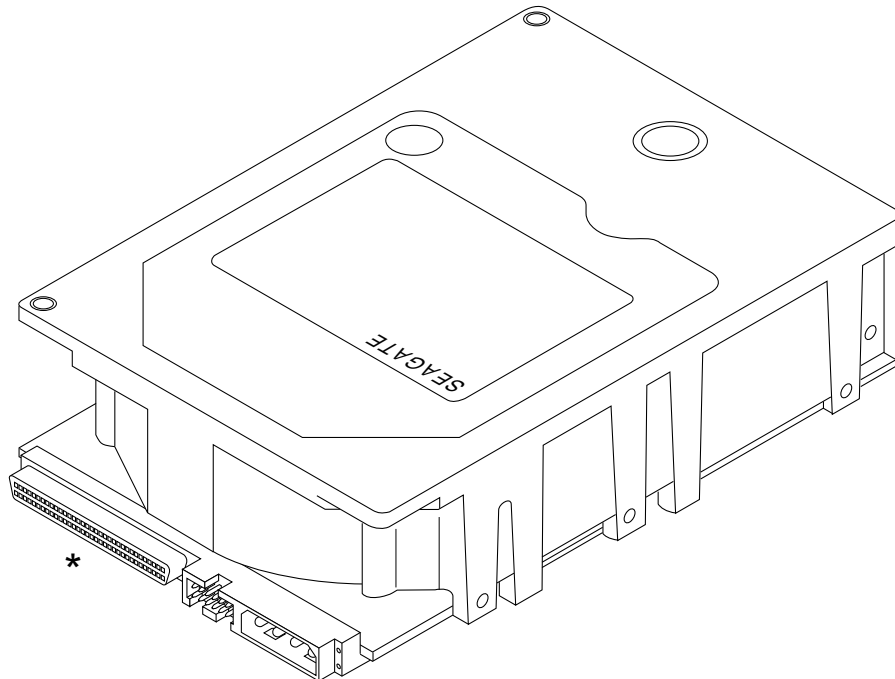

***I/O connector shown is on models ST12400W/WD drives.
Model ST12400WC has a single 80 pin connector.**

Figure 1-1. Hawk 2 family (Wide SCSI bus) drive

2.0 Applicable standards and reference documentation

The drive has been developed as a system peripheral to the highest standards of design and construction. The drive depends upon its host equipment to provide adequate power and environment in order to achieve optimum performance and compliance with applicable industry and governmental regulations. Special attention must be given in the areas of safety, power distribution, shielding, audible noise control, mechanical mounting and temperature regulation.

2.1 Standards

The ST12400 Wide SCSI bus drive family complies with Seagate standards as noted in the appropriate sections of this specification and the Seagate SCSI-2/SCSI-3 Interface Specification, P/N 77738479 (Vol. 2, Version 2).

The ST12400 wide family is a UL Recognized component per UL 1950 and a CSA Certified component per CAN/CSA-C22.2 No. 950-M89. It also meets the requirements of DIN VDE 0805/05.90 and EN60950: 1988 (IEC 950).

The ST12400 wide family drives, as delivered, are designed for system integration and installation into a suitable enclosure prior to use. As such the ST12400 wide family drives are supplied as a sub-assembly and are not subject to Subpart J of Part 15 of the FCC Rules and Regulations nor the Radio Interference Regulations of the Canadian Department of Communications. However, the units have been tested using proper shielding and grounding and found to be compliant with Class A limits of the FCC Rules and the Regulations of The Canadian Department of Communications.

The physical design characteristics of the ST12400 wide family serve to minimize radiation when installed in an enclosure that provides reasonable shielding. As such, the ST12400 wide is capable of meeting the Class B limits of the FCC Rules and Regulations of the Canadian Department of Communication. However, it is the users responsibility to assure that the ST12400 wide meets the appropriate EMI requirements in their system. Shielded I/O cables may be required if the enclosure does not provide adequate shielding. If the I/O cables are external to the enclosure, shielded cables should be used, with the shields grounded to the enclosure and to the host controller.

Caution. To avoid potential service problems, observe the following precautions:

The Manufacturers installed labels must not be removed from the drive or covered with additional labels, as they contain information required when servicing the product.

2.2. Applicable reference documents

Installation Guide	Seagate P/N 77767465
Product Manual - SCSI-2/SCSI-3 Interface	Seagate P/N 77738479
ANSI Small Computer System Interface (SCSI): Document Number ANSI3.131-1986 (X3T9/84.40 Rev. 1B) (X3T9.2/82-2 Rev. 17B), X3T9.2/86-109 Revision 10H (SCSI-2) and X3T9.2/92-184 Rev. 4 (SCSI-3).	

Package Test Specification Seagate P/N 30190-001 (under 100 lbs.)

Package Test Specification Seagate P/N 30191-001 (over 100 lbs.)

In case of conflict between this document and any referenced document, this document shall take precedence.

3.0 General description

The drives are a member of a family of low cost, high performance, highly reliable, random access storage devices designed to meet the needs of the OEM marketplace.

The drive records and recovers data on 3.7 inch (95 mm) fixed discs.

The drive supports the Small Computer System Interface (SCSI-1, SCSI-2 and SCSI-3) as described in the ANSI SCSI Interface Specifications to the extent described in this product specification (Volume 1). This manual defines the product performance characteristics of the ST12400 wide family of drives, together with the SCSI-2/SCSI-3 Interface Product Manual P/N 77738479 (Vol. 2, Version 2) which describes the general interface characteristics of this and other families of Seagate 3.5-inch drives.

The drive interface supports multiple initiators, disconnect/reconnect, self configuring host software and automatic features that relieve the host from the necessity of knowing the physical characteristics of the targets (logical block addressing is used).

The Head/Disc Assembly (HDA) is environmentally sealed at the factory. Air recirculates within the HDA through a nonreplaceable filter to maintain a contamination free head/disc environment.

Refer to Figure 3.0-1 for an exploded view of the drive. NEVER disassemble the Head/Disc Assembly (HDA). This exploded view is for information only. Do not attempt to service items in the sealed environmental enclosure (heads, media, actuator, etc.) as this requires special facilities. The drive contains no parts replaceable by the user. The drive warranty is voided if the HDA is opened.

The ST12400 wide family drives use a dedicated landing zone at the innermost radius of the media to eliminate the possibility of destroying or degrading data by landing in the data zone. The drive automatically goes to the landing zone when the power is removed.

The ST12400 wide family drives incorporate an automatic shipping lock which prevents potential damage to the heads and discs that result from movement during shipping and handling. The shipping lock disengages when power is applied to the drive and the head load process begins.

The ST12400 wide family drives decode Track 0 location from the dedicated servo surface to eliminate mechanical transducer adjustments and related reliability concerns.

The ST12400 wide family drives use a high performance actuator assembly that consists of a low inertia, balanced, patented, straight arm design that provides excellent performance with minimum power dissipation.

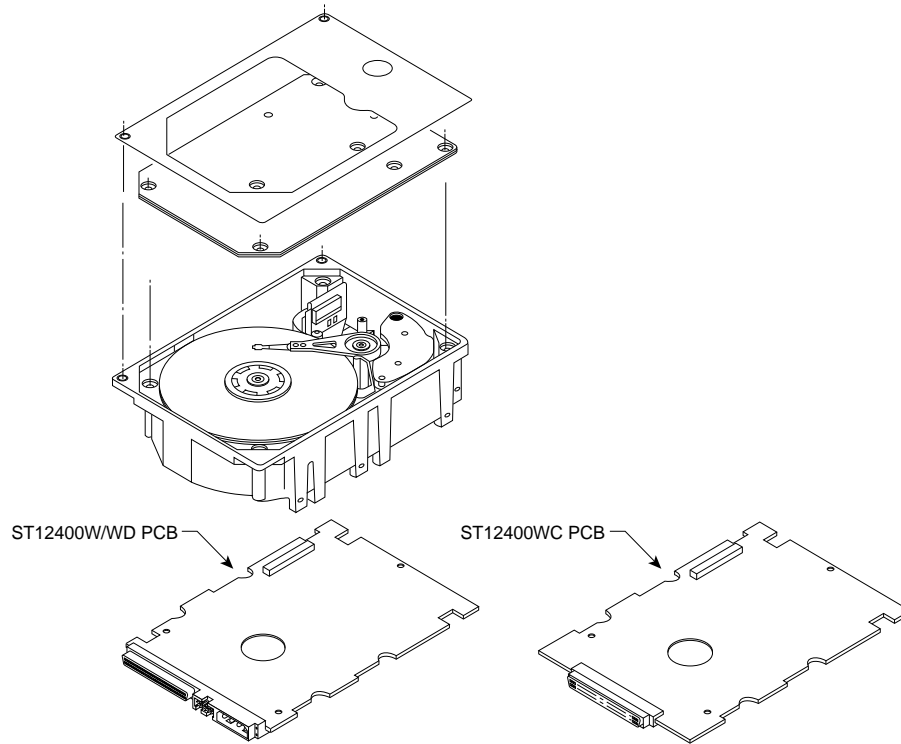

Figure 3.0-1. Hawk 2 family (Wide bus) drive

4.0 Standard features

The Hawk 2 Family (Wide bus) has the following standard features:

- Integrated SCSI Controller
- Differential SCSI drivers and receivers
- 8 or 16 bit parallel data transfer
- Asynchronous and Synchronous data transfer protocol
- Firmware downloadable via SCSI interface
- Selectable sector size from 256 to 4096 bytes/sector
- Programmable sector reallocation scheme
- Flawed sector reallocation at format time
- Programmable auto write and read reallocation
- Reallocation of defects on command (Post Format)
- 96 bit Reed-Solomon error correcting code
- Sealed Head/Disc Assembly
- No preventative maintenance or adjustment required
- Dedicated head landing zone
- Automatic shipping lock
- Automatic Thermal Compensation
- Patented Tri-Phase Servo with embedded Grey Code track address to guarantee servo positioning.
- Self diagnostics performed at power on
- 1:1 Interleave
- Zoned Bit Recording (ZBR)
- Vertical, horizontal, or top down mounting
- Dynamic spindle brake
- Synchronous spindle capability
- 256 K byte data buffer

4.1 Performance

- Programmable multi-segmentable cache buffer
- 5411 RPM Spindle. Average latency = 5.54 ms
- Command Queuing of up to 64 commands per initiator
- Background processing of queue
- Supports start and stop commands
- Provides synchronized spindle capability
- Low audible noise for office environment
- Low power consumption

4.1.1 Reliability

- 500,000 hour MTBF
- Adaptive seek velocity. Improved seek performance
- LSI circuitry
- Balanced low mass rotary voice coil actuator
- 5 year warranty

4.2 Unformatted and formatted capacities

Formatted capacity depends on the number of spare reallocation sectors reserved and the number of bytes per sector. The following table shows some typical formatted capacities.

Spare Sectors or Cylinders Reserved for reallocation	ST12400W/WD/WC	
	512*	1024*
	MB	
No Spares	2165	2279
12 Spare Sectors per cyl. 2 Spare Cylinders per Unit**	2148	2245
One Spare Sector per cyl. 2 Spare Cyl. per Unit**	2162	2275
Unformatted Capacity	2537	

***Bytes per sector.** Sector size selectable at format time. Users having the necessary equipment may modify the data block size before issuing a format command and obtain different formatted capacities than those listed. User available capacity depends on spare reallocation scheme selected. See Mode Select Command and Format Command in the SCSI Interface Product Manual P/N 77738479.

****Spare cylinders** are on the inner tracks.

The standard OEM model is as follows:

	Formatted Data Block Size* 512 Byte/Sector	Unformatted
ST12400W/WD/WC	2148 MB	2537 MB

*Twelve spare sectors per cylinder (all 12 spare sectors are on one track), two spare cylinders/unit.

4.3 Options (factory installed)

The capacities shown in paragraph 4.2 are available upon request. Other capacities can be ordered depending on sparing scheme and sector size requested.

The following options are incorporated at the time of production. See Section 12.0.

- Front panel (green LED) - See Figure 3.0-1
- Installation Guide P/N 77767465
- 1 MB data buffer

4.4 Optional accessories (user installed)

The following accessories are available. All kits may be installed in the field. See Section 13.0.

- Front Panel Kit (with green LED) - See Figure 3.0-1
- Single Unit shipping pack kit
- Installation Guide P/N 77767465
- Adapter Accessory Frame Kit P/N 75790701 (adapts 3.5-inch ST12400W/WD drive to fit in 5.25-inch drive mounting space, does not work for model ST12400WC).

4.5 Installation

For option jumper locations and definitions refer to Figure 10.1-1a and 10.1-1b. Drive default mode parameters are not normally needed for installation. Refer to Section 11.3.2 for default mode parameters if they are needed.

- Ensure that the SCSI ID of the drive is not the same as the host adapter. Host adapters probably use SCSI ID 7 or 15.
- If multiple devices are on the bus set the drive SCSI ID to one that is not presently used by other devices on the bus.
- If the drive is the only device on the bus, attach it to the end of the SCSI bus cable. Terminators must be installed external to the drive. These external terminators must be provided by the user, systems integrator or host equipment manufacturer.
- If the drive is attached to a bus that contains other devices, and the new drive is not attached to the end of the bus, terminators should not be installed at the new drive.
- Set all appropriate option jumpers for desired operation prior to power on. If jumpers are changed after power has been applied, recycle the drive power to make the new settings effective.
- Installation instructions are provided by host system documentation or with any additionally purchased drive installation software. If necessary see section 14.0 for Seagate support services telephone numbers.

Formatting

- It is not necessary to low level format this drive. The drive is shipped from the factory low level formatted in 512 byte sectors.
- Reformat the drive if one of the following occurs.
 - A different sector size is selected.
 - A different spare sector allocation scheme is selected.

5.0 Performance characteristics

5.1 Internal drive characteristics (transparent to user)

ST12400W/WD/WC		
Drive Capacity	2537	MByte (UNF)
Read/Write Heads	19	Data (Max)
Bytes/Track	50,945	Bytes (Avg)
Bytes/Surface	131.3	Mbytes (UNF)
Tracks/Surface, Total	2621	Tracks (user accessible)
Tracks/Inch	3000	TPI
Servo Heads	1	
Internal Data Rate	26.8 to 45.6	Mbits/sec (variable with zone)
Disc Rotational Speed	5411 ±0.5%	r/min
Average Rotational Latency	5.54	ms

5.2 SCSI Seek, Read and Write performance characteristics (visible to user) [8]

Refer to Section 11.7 and to the SCSI-2/SCSI-3 Interface Product Manual 77738479 for additional timing details.

5.2.1 Seek time

			Drive Level	
			ST12400W/WD/WC	
			Read	Write
			ms	
Average	-	Typical [3]*	9.3	10.8
		Max. [2]	11.1	12.6
Single Track	-	Typical [3]	1.0	1.7
		Max. [2]	1.5	2.0
Full Stroke	-	Typical [3]	21.0	22.5
		Max. [2]	23.0	24.0
			Including Controller Overhead	
			(without disconnect) [1] [4]	
			ST12400W/WD/WC	
			Read	Write
			ms	
Average	-	Typical [3]	10.3	11.8
		Max. [2]	12.1	13.6
Single Track	-	Typical [3]	2.0	2.7
		Max. [2]	2.5	4.0
Full Stroke	-	Typical [3]	22.0	23.5
		Max. [2]	24.0	25.0

5.2.2 Format drive command execution time (minutes) [1]

	ST12400W/WD/WC
Maximum (with verify)	45 Min.
Maximum (no verify)	31 Min.

*[] All notes are listed in Section 5.3.1.

**5.2.3 Read data command execution time [4]
(512 byte sector size, without disconnect and with read look ahead cache disabled)
latency time is included.**

- a. From CDB reception to the drive request for the first data byte to be transferred to the Host

	ST12400W/WD/WC
	ms
1. Typical (Zero Stroke Seek)	7.32 [3]*
2. Typical (Average Seek)	16.84 [3]
3. Maximum (Full Stroke Seek)	31.38 [2]

- b. Single Sector Read and Transfer of data to Host (time from receipt of last byte of the CDB to the request for a status byte transfer to Host) [7].

	ST12400W/WD/WC
	ms
1. Typical (Zero Stroke Seek)	7.42 [3]
2. Typical (Average Seek)	16.95 [3]
3. Maximum (Full Stroke Seek)	31.49 [2]

**5.2.4 Write data command execution time [4]
(512 byte sector size, without disconnect and with read look ahead disabled) latency
time is included.**

- a. From CDB reception to the request for the first byte of write data from the Host.

1. Typical	1.49 ms	2. Maximum	1.61 ms
------------	---------	------------	---------

- b. Single Sector Write and Data Transfer from Host [7] [6]

(Time from receipt of the last byte of the CDB to the request for a completion status transfer to the Host)

	ST12400W/WD/WC
	ms
1. Typical (Zero Stroke Seek)	7.72 [3]
2. Typical (Average Seek)	17.10 [3]
3. Maximum (Full Stroke Seek)	31.93 [2]

*[] All notes are listed in Section 5.3.1.

5.3 Generalized performance characteristics

Minimum Sector Interleave 1 to 1

Data Buffer To/From Disc Media

Data transfer rate (\leq 1 sector) - 512 Byte Sector

Min. [4]* 3.35 MByte/sec
 Avg. [4] 4.59 MByte/sec
 Max. [4] 5.35 MByte/sec

Data Buffer To/From Disc Media

Data Transfer Rate (< 1 Track) - 512 Byte Sector

Min. [4] 2.88 MByte/sec divided by (Interleave Factor)
 Avg. [4] 3.94 MByte/sec divided by (Interleave Factor)
 Max. [4] 4.6 MByte/sec divided by (Interleave Factor)

SCSI Interface Data

Transfer Rate (Asynchronous) [5]

	ST12400W/WC	ST12400WD
-Maximum Instantaneous	5.2** MBytes/sec	3.3 MBytes/sec
-Maximum Average	3.1 MBytes/sec	2.4 MBytes/sec

Sector Sizes 512 user data blocks (default)
 Variable (256 to 4096) in even sector sizes

Synchronous Transfer Rate

From 1.25 MByte/sec to 20.0 MBytes/sec (See section 11.5.)

Read/Write consecutive sectors on a track	Yes
Flaw reallocation performance impact (For flaws reallocated using the spare sectors per track reallocation scheme.)	Negligible
Flaw reallocation performance impact (For flaws reallocated using the spare sectors per cylinder reallocation scheme.)	Negligible
Flaw reallocation performance impact (For flaws reallocated using the spare tracks per volume reallocation scheme.)	35 ms (typical)
Overhead time for head switch (512 byte sectors)	1 ms
Overhead time for one track cylinder switch	<3 ms Typical
Average rotational latency	5.54 ms

* [] All notes are listed in Section 5.3.1.

** Assumes system ability to support 5.2 Mb/s and no cable loss.

5.3.1 Notes for sections 5.2 and 5.3.

- [1] Execution time measured from receipt of the last Byte of the Command Descriptor Block (CDB) to the request for a Status Byte Transfer to the Initiator (excluding connect/disconnect).
- [2] Maximum times are specified over the worst case conditions of temperature, voltage margins and drive orientation. When comparing specified seek times, care should be taken to distinguish between typical seek times and maximum seek times. The best comparison is obtained by system benchmark tests conducted under identical conditions.
- [3] Typical Seek values are measured under nominal conditions of temperature, voltage, and horizontal orientation as measured on a representative sample of drives.
- [4] Assumes no errors and no sector has been relocated.
- [5] Rate measured from the start of the first sector transfer to or from the Host.
- [6] Assumes the Initiator immediately sends Write Data to the drive when requested.
- [7] Command execution requires a data transfer phase (data to or from the disc media). Assumes the initiator is instantly ready to send/receive the data when the drive generates first request for a data byte transfer, and assumes an average data transfer rate between the drive and the Initiator as specified in section 5.3.
- [8] All performance characteristics assume that automatic adaptive temperature compensation is not in process when the SCSI command is received. A SCSI command being executed is not interrupted for automatic adaptive temperature compensation. If adaptive thermal compensation is in process when a SCSI command is received, the command is queued until the compensation for the specific head being compensated completes. When compensation completes for the specific head being compensated, the first queued SCSI command is executed. When execution of the first queued command is complete, the drive continues the compensation for the remaining head(s). The above procedure continues until compensation for all heads is completed or until one minute has elapsed. If the compensation for all heads is not complete in one minute the drive performs compensation for all of the remaining heads sequentially without any interruption. The drive initiates an automatic adaptive temperature compensation cycle approximately one minute after power-on, and approximately once every 10 minutes thereafter. Automatic adaptive temperature compensation takes less than 0.1% of bus time. Automatic temperature compensation also occurs at other times, but should be transparent to the user (e.g., during format, Rezero Command, at spindle up, during read error recovery, and during Reassign Block functions). A Rezero command can be used to reset the thermal compensation timer back to its start so that the host can know when the interruption for thermal compensation will occur.

5.4 Start/stop time

After DC power has been applied, the drive becomes ready within 25 seconds if the Motor Start Option is disabled (i.e. the motor starts as soon as the power has been applied). During this time the drive responds to some commands over the SCSI interface* in less than 3 seconds. Stop time is less than 20 seconds from removal of DC power.

*See SCSI Interface Manual P/N 77738479.

If the Motor Start Option is enabled the internal controller accepts the commands listed in the SCSI Interface Product Manual* less than 3 seconds after DC power has been applied. After the Motor Start Command has been received the drive becomes ready for normal operations within 15 seconds. The Motor Start Command can also be used to command the drive to stop the spindle*.

There is no power control switch on the drive.

5.5 Prefetch/multi-segmented cache control

The drive provides prefetch (read look-ahead) and multi-segmented cache control algorithms that in many cases can enhance system performance. "Cache" as used herein refers to the drive buffer storage space when it is used in "cache" operations. To select prefetch and cache features the host sends the Mode Select command with the proper values in the applicable bytes in Mode Page 08h*. Prefetch and cache operation are independent features from the standpoint that each is enabled and disabled independently via the Mode Select command. However, in actual operation the prefetch feature overlaps cache operation somewhat as is noted in sections 5.5.1 and 5.5.2.

All default cache and prefetch Mode parameter values (Mode Page 08h) for standard OEM versions of this drive family are given in Tables 11.3.2-1 through 11.3.2-4.

5.5.1 Cache operation

In general, 240 kBytes of the 256 kBytes of physical buffer space in the drive can be used as storage space for cache operations (984 KB of 1 MB for drives having 1 MB optional buffer). The buffer can be divided into logical segments (Mode Select Page 08h, byte 13) from which data is read and to which data is written. The drive maintains a table of logical block disk medium addresses of the data stored in each segment of the buffer. If cache operation is enabled (RCD bit = 0 in Mode Page 08h, byte 2, bit 0. See SCSI Interface Product Manual*), data requested by the host with a Read command is retrieved from the buffer (if it is there), before any disc access is initiated. If cache operation is not enabled, the buffer (still segmented with required number of segments) is still used, but only as circular buffer segments during disc medium read operations (disregarding Prefetch operation for the moment). That is, the drive does not check in the buffer segments for the requested read data, but goes directly to the medium to retrieve it. The retrieved data merely passes through some buffer segment on the way to the host. All data transfers to the host are in accordance with "buffer-full" ratio rules. See explanations associated with Mode page 02h (disconnect/reconnect control) in the SCSI Interface Product Manual*.

The following is a simplified description of a read operation with cache operation enabled:

Case A - A Read command is received and the first logical block (LB) is already in cache:

1. Drive transfers to the initiator the first LB requested plus all subsequent contiguous LB's that are already in the cache. This data may be in multiple segments.
2. When the requested LB is reached that is not in any cache segment, the drive fetches it and any remaining requested LB's from the disc and puts them in a segment of the cache. The drive transfers the remaining requested LB's from the cache to the host in accordance with the disconnect/reconnect specification mentioned above.
3. If the prefetch feature is enabled, refer to section 5.5.2 for operation from this point.

*SCSI Interface Product Manual P/N 77738479.

Case B - A Read command requests data, the first LB of which is not in any segment of the cache:

1. The drive fetches the requested LB's from the disc and transfers them into a segment, and from there to the host in accordance with the disconnect/reconnect specification referred to in case A.
2. If the prefetch feature is enabled, refer to section 5.5.2 for operation from this point.

Each buffer segment is actually a self-contained circular storage (wrap-around occurs), the length of which is an integer number of disc medium sectors. The wrap-around capability of the individual segments greatly enhances the buffer's overall performance as a cache storage, allowing a wide range of user selectable configurations, which includes their use in the prefetch operation (if enabled), even when cache operation is disabled (see section 5.5.2). For the ST12400 wide family the *number* of segments may be selected using the Mode Select command, but the *size* can not be directly selected. *Size* is selected only as a by-product of selecting the segment *number* specification. The size in Kbytes of each segment is reported by the Mode Sense command page 08h, bytes 14 and 15. If a size specification is sent by the host in a Mode Select command (bytes 14 and 15) no new segment size is set up by the drive, and if the "STRICT" bit in Mode page 00h (byte 2, bit 1) is set to one, the drive responds as it does for any attempt to change unchangeable parameters (see SCSI I/O Product Manual*). The ST12400 wide family of drives supports operation of any integer number of segments from 1 to 16. Divide the 245,760 bytes (or 1,007,616 bytes for optional 1 MB buffer) in the buffer by the number of segments to get the size (in bytes) of each segment.

5.5.2 Prefetch operation

If the Prefetch feature is enabled, data in contiguous logical blocks on the disc immediately beyond that which was requested by a Read command can be retrieved and stored in the buffer for immediate transfer from the buffer to the host on subsequent Read commands that request those logical blocks (this is true even if "cache" operation is disabled). Though the prefetch operation uses the buffer as a "cache", finding the requested data in the buffer is a prefetch "hit", not a "cache" operation "hit". Prefetch is enabled using Mode Select page 08h, byte 12, bit 5 (Disable Read Ahead - DRA bit). DRA bit = 0 enables prefetch. Since data that is prefetched replaces data already in some buffer segment(s), the host can limit the amount of prefetch data to optimize system performance. The drive never prefetches more logical blocks than the number specified in the prefetch logical blocks ceiling bytes (8 and 9) of Mode page 08h.

During a prefetch operation, the drive crosses a cylinder boundary to fetch more data *only* if the Discontinuity (DISC) bit is set to one in bit 4 of byte 2 of Mode parameters page 08h.

The operation of the prefetch feature (when enabled by DRA = 0) can be modified to an adaptable prefetch mode, wherein prefetch is disabled as long as two sequential read operations are *not* for contiguous blocks of data. If two sequential Read operations request contiguous logical blocks of data, the drive automatically enables the prefetch feature for the end of the second Read operation. As long as sequential Read operations request contiguous LB's of data, prefetch operation remains enabled.

If the host uses software interleave, there will not likely ever be two sequential Read operations for contiguous LB's, so the adaptive prefetch feature keeps prefetch disabled, even if the DRA bit enables it. Adaptive prefetch is enabled when the IC (Initiator Control) bit (Mode page 08h, byte 2, bit 7) is set to 0 and when DRA = 0 (prefetch enabled).

*SCSI-2/SCSI-3 Interface Product Manual, P/N 77738479.

5.6 Caching write data

Write caching is a write operation by the drive that makes use of a drive buffer storage area where the data to be written to the medium is stored in one or more segments while the drive performs the write command.

Write caching is enabled along with read caching. For write caching, the same buffer space and segmentation is used as set up for read functions. The buffer segmentation scheme is set up or changed independently, having nothing to do with whether or not read and write caching is enabled or disabled. When a write command is issued, the cache is first checked to see if any logical blocks that are to be written are already stored in the cache from a previous read or write command. If there are, the respective cache segments are cleared. The new data is cached for subsequent Read commands.

If the number of write data logical blocks exceeds the size of the segment being written into when the end of the segment is reached, the data is written into the beginning of the same cache segment, overwriting the data that was written there at the beginning of the operation. However, the drive does not overwrite data that has not yet been written to the medium.

Tables 11.3.2-1 through 11.3.2-4 show Mode default settings for the Hawk 2 (wide bus) family of drives.

5.7 Synchronized spindle operation

The synchronized spindles operation allows several drives operating from the same host to operate their spindles at the same synchronized rotational rate. Drives operating in a system in synchronized mode can increase the system capacity and transfer rate in a cost effective manner.

For "W" and "WD" models the interface consists of a twisted pair cable that connects the drives in the synchronized system in a daisy-chain configuration as shown in Figure 5.7-1. For "WC" models the reference index signal ("SYNC") signal is on pin J1-37 of the 80-pin I/O connector. Master/Slave operation is autoarbitrated by each drive after head load. Alternatively, each drive in the system can be configured by the host (using the Mode Select command Rigid Disc Drive Geometry page*) to operate in either the master or slave mode.

After loading heads, a drive autoarbitrates for occurrences of the Reference Index Signal (REFIND+). If the drive detects no REFIND+ signal on the line, it assumes master status and begins generating the REFIND+ signal. This signal will not be visible on the line until the last drive has powered up, since any unpowered drive holds the line low.

Using Mode Select command, drives can be re-configured by the host to be master or slave any time after the last drive has powered up. The master provides the reference signal to which all other drives phase lock, including the master. The master can be a drive or the host computer. All the drives may be configured as slaves, allowing the host to provide the REFIND+ signal. All drives default to the synchronized mode when powered up, unless J6 pins 5 and 6 are jumpered.

Each drive can be configured (jumpered) for the non-synchronized mode in which it ignores any reference signal that might be present. The connection of the synchronized reference signal to the host is required only if the host is to provide the reference signal. If the host does not provide the reference signal, the host should not be connected.

*SCSI Interface Product Manual P/N 77738479.

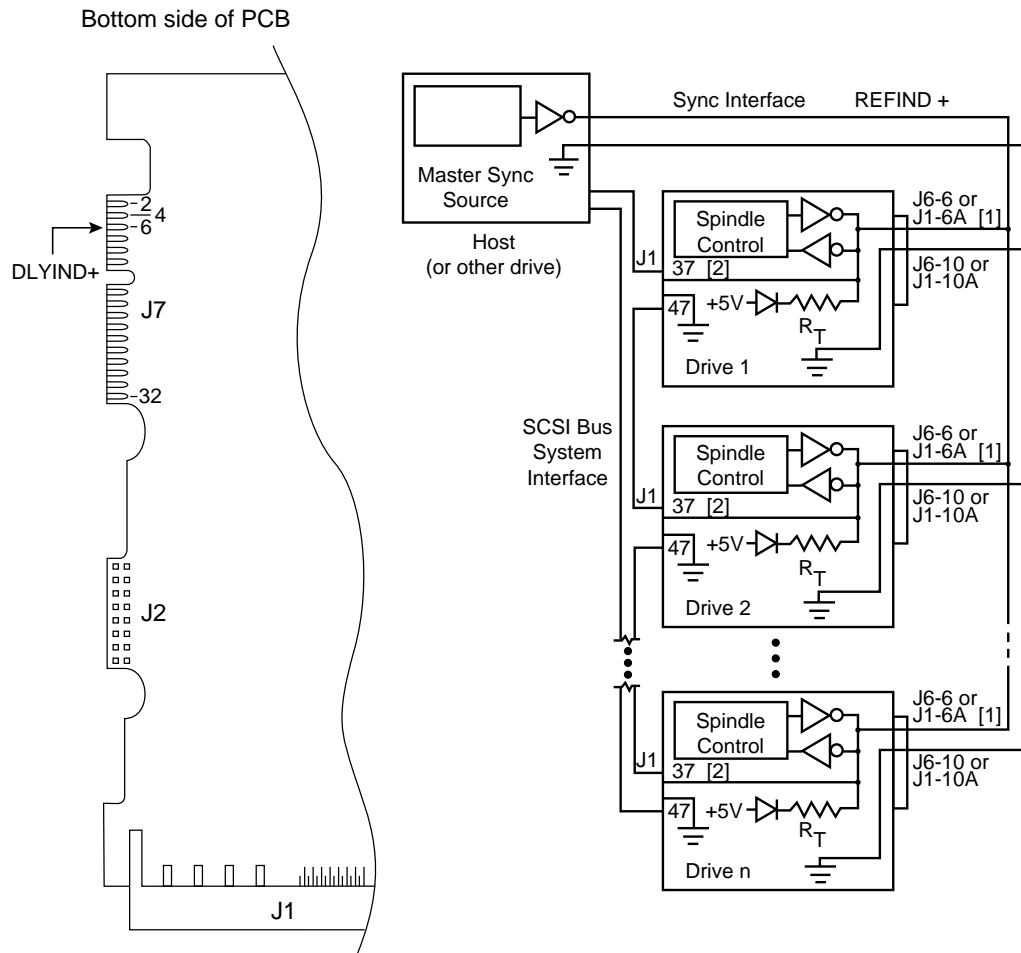

Notes:

- [1] Configuration select header. See Figure 10.1-1a, 10.1-1b and 10.2.1-1.
- [2] This connection available only on Model ST12400WC.

Figure 5.7-1. Synchronized drive interconnect diagram

The servo/read-write LSI on the master drive provides the reference signal (REFIND+). It is a 90.18 Hz crystal generated signal. The signal is normally false/negated (nominal 0 V) and makes a transition to the true/asserted (nominal +5 V) level to indicate the reference position during the revolution period. The trailing (falling) edge of the reference signal is used by the master and the slave drives to phase lock their spindles. A maximum of 10 seconds is allowed for a slave to synchronize with the reference signal. The DLYIND+ signal (available on J7-6 See Figure 5.7-1) of each synchronized drive shall occur 85.2 μsec \pm 20 μsec after the REFIND+ signal. Figure 5.7-2 shows the characteristics of the reference signal.

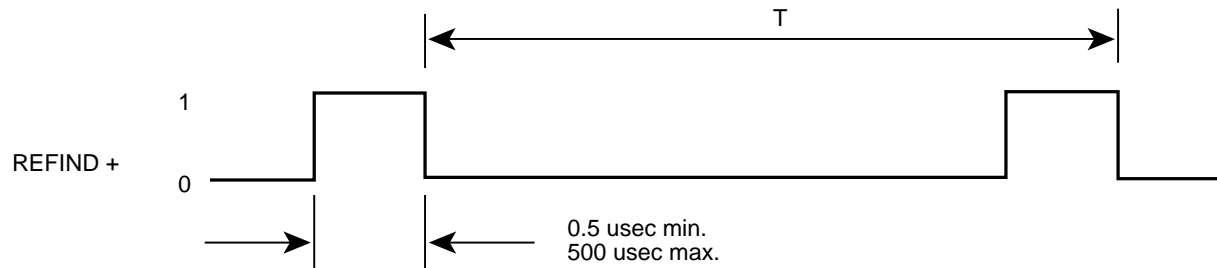

$T = 0.0111$ second ($\pm 1.0\%$ max); ± 10 μsec cycle to cycle variance;

Figure 5.7-2. Synchronized reference signal characteristics

The physical characteristics of the synchronized spindle interface are described in Section 10.2.

SCSI Interface Factors

The Rotational Position Locking (RPL) field in byte 17 (bits 0 and 1) of the Rigid Disc Drive Geometry mode parameters page (page 04h) is used for enabling/disabling spindle synchronization mode*. If the target fails to achieve synchronization, it shall create a unit attention to all initiators. The sense key shall be set to UNIT ATTENTION and the additional sense code set to RPL STATUS CHANGE. However, in automatic arbitration mode, UNIT ATTENTION and the RPL STATUS CHANGE is not set.

If subsequent to achieving synchronization the target detects a change of synchronization:

- 1) and, if the logical unit is not presently executing an I/O process for the initiator, the target shall create a unit attention condition. The sense key shall be set to UNIT ATTENTION and the additional sense code set to RPL STATUS CHANGE.
- 2) and, if the logical unit is presently executing an I/O process and no other error occurs, the target shall return CHECK CONDITION status. The sense key shall be set to RECOVERED ERROR if the target is able to complete the I/O process or HARDWARE ERROR if the target is unable to complete the I/O process. The additional sense code is set to RPL STATUS CHANGE.

The drive may be operated with a rotational skew when synchronized. The rotational skew is applied in the retarded direction (lagging the synchronized spindle master control). A rotational offset of up to 255/256 of a revolution lagging may be selected. The amount of offset is selected by using the Mode Select command, Rigid Disc Drive Geometry page (page 04), byte 18*. The value in byte 18 (0 - FFh) is the numerator of a fractional multiplier that has 256 as the denominator. For example, 40h selects 40h/FFh or 1/4 of a revolution lagging skew, 80h selects 1/2 revolution lagging skew and etc. Since the drive supports all offset values from 0 to 255, values sent by the initiator are not rounded off. The drive translation of the digital offset values to physical rotational offsets results in offset values whose phase error lies within the + or - 20 μ sec phase error with respect to the supplied 90.18 Hz reference signal.

The drive does not have the capability to adjust the rotational offset value requested by the initiator to a physical offset in the drive that corresponds in any way to sector boundaries or changes in ZBR zones. Such correspondences or changes, if required, must be formulated by the initiator in order for it to calculate the value of offset it sends to the drive.

*SCSI Interface Product Manual P/N 77738479.

6.0 Reliability specifications

The following reliability specifications assume correct host/drive operational interface, including all interface timings, power supply voltages, and environmental requirements.

Seek Errors	Less than 1 in 10^7 seeks
Read Error Rates [1]	
Unrecovered Data	Less than 1 sector in 10^{14} bits transferred
Miscorrected Data	Less than 1 sector in 10^{21} bits transferred
MTBF	500,000 hours
Service Life	5 years
Preventive Maintenance	None required

Note.

[1] Error rate specified with automatic retries and data correction with ECC enabled and all flaws reallocated.

6.1 Error rates

The error rates stated in this specification assume the following:

The drive is operated per this specification using DC Power as defined in this specification (see Section 7.2).

- The drive has been formatted with the SCSI FORMAT commands.
- Errors caused by media defects or host system failures are excluded from error rate computations. Refer to Paragraph 8.0, Media Characteristics.

6.1.1 Read errors

Before determination or measurement of read error rates:

- The data that is to be used for measurement of read error rates must be verified as being written correctly on the media.
- All media defect induced errors must be excluded from error rate calculations.

6.1.2 Environmental interference

When evaluating systems operation under conditions of Electromagnetic Interference (EMI), the performance of the drive within the system shall be considered acceptable if the drive does not generate an unrecoverable condition.

An unrecoverable error, or condition, is defined as one that:

1. Is not detected and corrected by the drive itself;
2. Is not capable of being detected from the error or fault status provided through the drive or SCSI interface; or
3. Is not capable of being recovered by normal drive or system recovery procedures without operator intervention.

6.1.3 Write errors

Write errors can occur as a result of media defects, environmental interference, or equipment malfunction. Therefore, write errors are not predictable as a function of the number of bits passed.

If an unrecoverable write error occurs because of an equipment malfunction in the drive, the error is classified as a failure affecting MTBF. Unrecoverable write errors are those which cannot be corrected within two attempts at writing the record with a read verify after each attempt (excluding media defects).

6.1.4 Seek errors

A seek error is defined as a failure of the drive to position the heads to the addressed track. There shall be no more than one recoverable seek error in 10^7 physical seek operations. After detecting an initial seek error, the drive automatically reseek to the addressed track up to 3 times. If a reseek is successful, the Extended Sense reports a seek positioning error (15h), no seek complete error (02h), or track follow error (09h), and the sense key reports a recovered error (1h). If all three reseek fail, a seek positioning error (15h) is reported with a Medium (3h) or Hardware error (4h) reported in the Sense Key. This is an unrecoverable seek error. Unrecoverable seek errors are classified as failures for MTBF calculations. Ref. section 5.1.1.2 of SCSI-2 Interface Product Manual P/N 77738479.

6.2 Reliability and service

6.2.1 Mean time between failure

The production disc drive shall achieve an MTBF of 500,000 hours when operated in a benign atmosphere at an average disc drive ambient temperature of 95°F (35°C) or less as measured per this Product Specification, paragraph 7.4.1. Short term excursions up to the specification limits of the operating environment will not affect MTBF performance.

The following expression defines MTBF:

$$\text{MTBF per measurement period} = \frac{\text{Estimated power-on operating hours in the period}}{\text{Number of drive failures in the period}}$$

Estimated power-on operation hours means power-up hours per disc drive times the total number of disc drives in service. Each disc drive shall have accumulated at least nine months of operation. Data shall be calculated on a rolling average base for a minimum period of six months.

Drive failure means any stoppage or substandard performance caused by drive malfunction.

6.2.2 Preventive maintenance

No routine scheduled preventive maintenance shall be required.

6.2.3 Service life

The drive shall have a useful service life of five years. Depot repair or replacement of major parts is permitted during the lifetime (6.2.4).

6.2.4 Service philosophy

Special equipment is required to repair the drive HDA. In order to achieve the above service life, repairs must be performed only at a properly equipped and staffed service and repair facility. Troubleshooting and repair of PCBs in the field is not recommended, because of the extensive diagnostic equipment required for effective servicing. Also, there are no spare parts available for this drive. Drive warranty is voided if the HDA is opened.

6.2.5 Installation

The drive is designed, manufactured, and tested with a "Plug in and Play" installation philosophy. This philosophy minimizes the requirements for highly trained personnel to integrate the drive into the OEM's system, whether in a factory or field environment.

The drive has been low level formatted at the factory and need not be reformatted.

6.2.6 Service tools

No special tools are required for site installation or recommended for site maintenance. Refer to Paragraph 6.2.4. The depot repair philosophy of the drive precludes the necessity for special tools. Field repair of the drive is not practical since there are no user purchasable parts in the drive.

6.2.7 Product Warranty

Beginning on the date of shipment to customer and continuing for a period of five years, Seagate warrants that each product (including components and sub-assemblies) or spare part that fails to function properly under normal use due to defect in materials or workmanship or due to non conformance to the applicable specifications will be repaired or replaced, at Seagate's option and at no charge to customer, if returned by customer at customer's expense to Seagate's designated facility in accordance with Seagate's Warranty Procedure. Seagate will pay for transporting the repaired or replacement item to customer. For more detailed warranty information refer to the Standard terms and conditions of Purchase for Seagate products.

7.0 Physical/electrical specifications

7.1 AC power requirements: None

7.2 DC Power requirements

The voltage and current requirements for a single drive are shown in the following table. Values indicated apply at the drive power connector.

Table 7.2-1. DC power requirements

	Single Ended (W/WC)		Differential (WD)	
	+5 V	+12 V	+5 V	+12 V
Voltage	+5 V	+12 V	+5 V	+12 V
Regulation [5]	±5%	±5%[2]	±5%	±5%[2]
Average Idle Current [1] [3]	0.43 A	0.57 A	0.57 A	0.66 A
Maximum Starting Current (Peak) [6]	0.8 A	2.4 A	0.9 A	2.4 A
Delayed Motor Start (Max) [4] [6]	0.6 A	0.4 A	0.6 A	0.4 A
Operating Current [7]				
Typ. [1]	0.78 A	0.68 A	1.05 A	0.78 A
Max. [1]	1.0 A	1.0 A	1.2 A	1.0 A
Max. (Peak)	-	2.4 A	-	2.4 A

- [1] Measured with average reading DC ammeter. Instantaneous +12 V current peaks will exceed these values.
- [2] A droop of up to -10% is permissible during power up. The ±5% must be maintained after the drive signifies that its power up sequence has been completed and that the drive is able to accept selection by the Host Initiator.
- [3] See +12 V current profile level T6 in Figure 7.2.2-1.
- [4] This condition occurs when the Motor Start Option is enabled and the drive has not yet received a Start Motor command.
- [5] See paragraph 7.2.1 "Conducted Noise Immunity".
- [6] Peaks of 0.90 A (nominal) on the +12 V will occur for no more than 100 ms total during the first 250 ms after power is applied.
- [7] Instantaneous peaks less than 5 msec. in duration are allowed.

General Notes from Table 7.2-1:

- At powerup, the motor current regulator limits the 12 volt current to a peak value of less than 2.4 amperes, although instantaneous peaks may exceed this value. These peaks should measure 5 msec. duration or less.
- Operating condition is defined as Random Seek Reads of 64 blocks.
- Minimum current loading for each supply voltage is not less than 30% of the maximum operating current shown.
- The +5 and +12 volt supplies shall employ separate ground returns.
- Where power is provided to multiple drives from a common supply, careful consideration for individual drive power requirements should be noted. Where multiple units are powered on simultaneously, the peak starting current must be available to each device.

7.2.1 Conducted noise immunity

Noise is specified as a periodic and random distribution of frequencies covering a band from DC to 10 MHz. Maximum allowed noise values given below are peak to peak measurements and apply at the drive power connector.

- +5 V = 150 mV pp from 0 to 100 kHz and 45 mA pp from 100 kHz to 10 MHz.
- +12 V = 150 mV pp from 0 to 100 kHz and 60 mA pp from 100 kHz to 10 MHz.

7.2.2 Power sequencing

The drive does not require power sequencing. The drive protects against inadvertent writing during power up and down. Daisychain operation requires that power be maintained on the terminated drive to ensure proper termination of the peripheral I/O cables.

7.2.3 12 V - current profile

Figure 7.2.2-1 identifies the drive +5 V and +12 V current profile. The current during the various times is as shown:

- T - Power is applied to the drive.
- T1 - Controller self tests are performed.
- T2 - Spindle begins to accelerate under current limiting after performing internal diagnostics. See Note 1 of Table 7.2-1.
- T3 - The spindle is up to speed and the Head-Arm restraint is unlocked.
- T4 - The heads move from the landing zone to the data area.
- T5 - The adaptive calibration sequence is performed.
- T6 - Calibration is complete and the drive is ready for reading and writing.

Note. All times and currents are typical. See Table 7.2-1 for maximum current requirements.

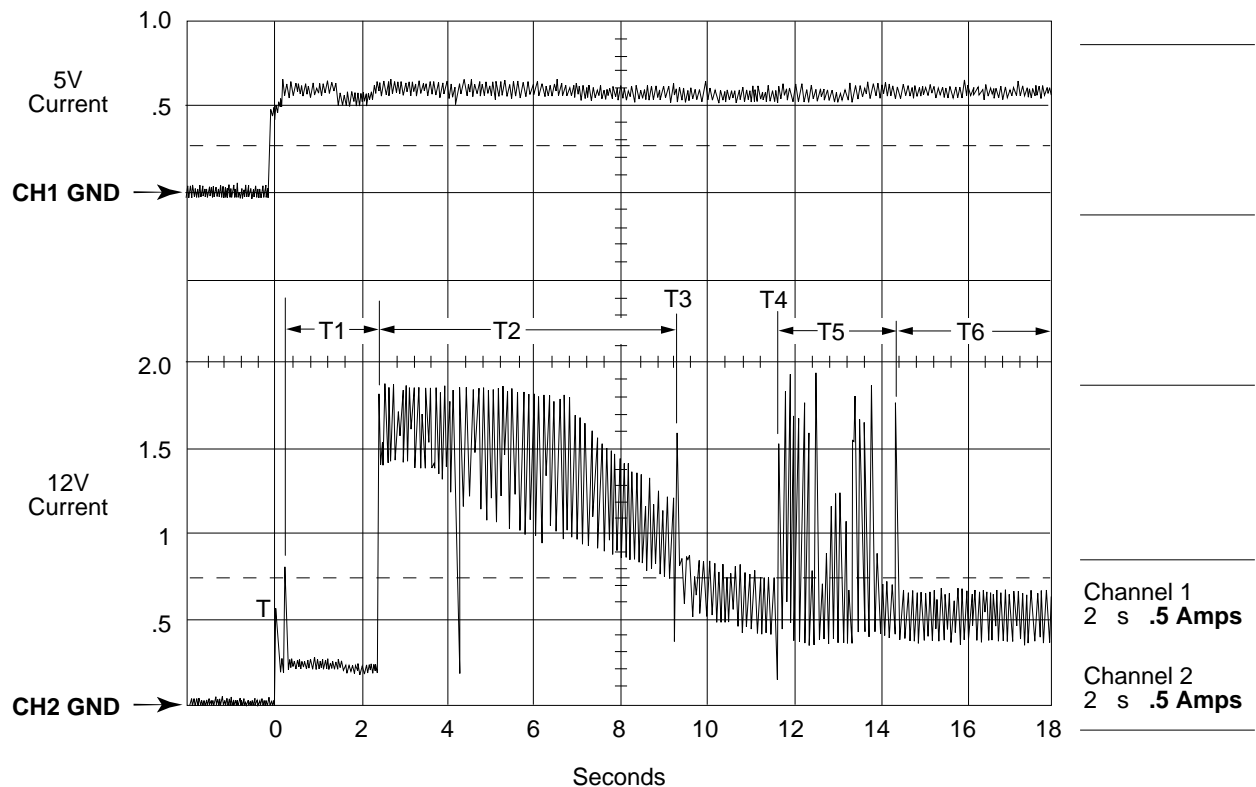

Figure 7.2.2-1. Typical ST12400 wide family drive +5 V and +12 V current profile

7.3 Heat/power dissipation

For drives with single ended interface circuits, typical operating power dissipation is 12.1 watts (41.3 BTUs per hour) of DC power average at nominal voltages. Typical power dissipation under idle conditions is 9.0 watts (30.7 BTUs per hour).

For drives having differential interface circuits, typical operating power dissipation is 14.6 watts (49.8 BTUs per hour) of DC power average at nominal voltages. Typical power dissipation under idle conditions is 10.8 watts (36.8 BTUs per hour).

7.4 Environmental limits

Temperature and humidity values experienced by the drive must be such that condensation does not occur on any drive part. Altitude and atmospheric pressure specifications are referenced to a standard day at 58.7°F (14.8°C). Maximum Wet Bulb temperature is 82°F (28°C).

7.4.1 Temperature

a. Operating

The drive meets all specifications over a 41°F to 122°F (5°C to 50°C) drive ambient temperature range with a maximum gradient of 36°F (20°C) per hour. The enclosure for the drive should be designed such that the temperatures at the locations specified in Table 7.4.1-1, column 1 are not exceeded. Air flow may be needed to achieve these temperature values. Operation at case temperatures above these values may adversely affect the drive's ability to meet specifications.

The MTBF specification for the drive is based on operating at an ambient temperature of 95°F (35°C) with no air flow. Occasional excursions to drive ambient temperatures of 50°C or 5°C may occur without impact to specified MTBF. To achieve the specified MTBF, the values of Table 7.4.1-1 Column 2 must be considered maximum average operating case temperatures. Continual or sustained operation at case temperatures above the values shown in Column 2 may degrade MTBF.

Table 7.4.1-1. PCB and HDA temperatures

Items in Figure 7.4.1-1	Column 1 Maximum Case Temperatures (°C) Operating 50°C Ambient [3]	Column 2 Typical Case Temperatures (°C) at 35°C Ambient [1]
HDA	60 [2]	56
U2	80	72
U8	65	50
Q2	64	63
Q13	72	67

Notes.

- [1] The temperatures in Column 2 were made in an enclosed box with no airflow at a pressure of one atmosphere, with random seeks.
- [2] No point on the top of the HDA shall exceed this temperature.
- [3] Ambient temperature is measured at the side of the drive 0.25" (6.4 mm) from the case. Air flow is 3.5 cfm, min.

b. Non-Operating

-40° to 158°F (-40° to 70°C) package ambient with a maximum gradient of 45°F (25°C) per hour. This specification assumes that the drive is packaged in the shipping container designed by Seagate for use with the drive.

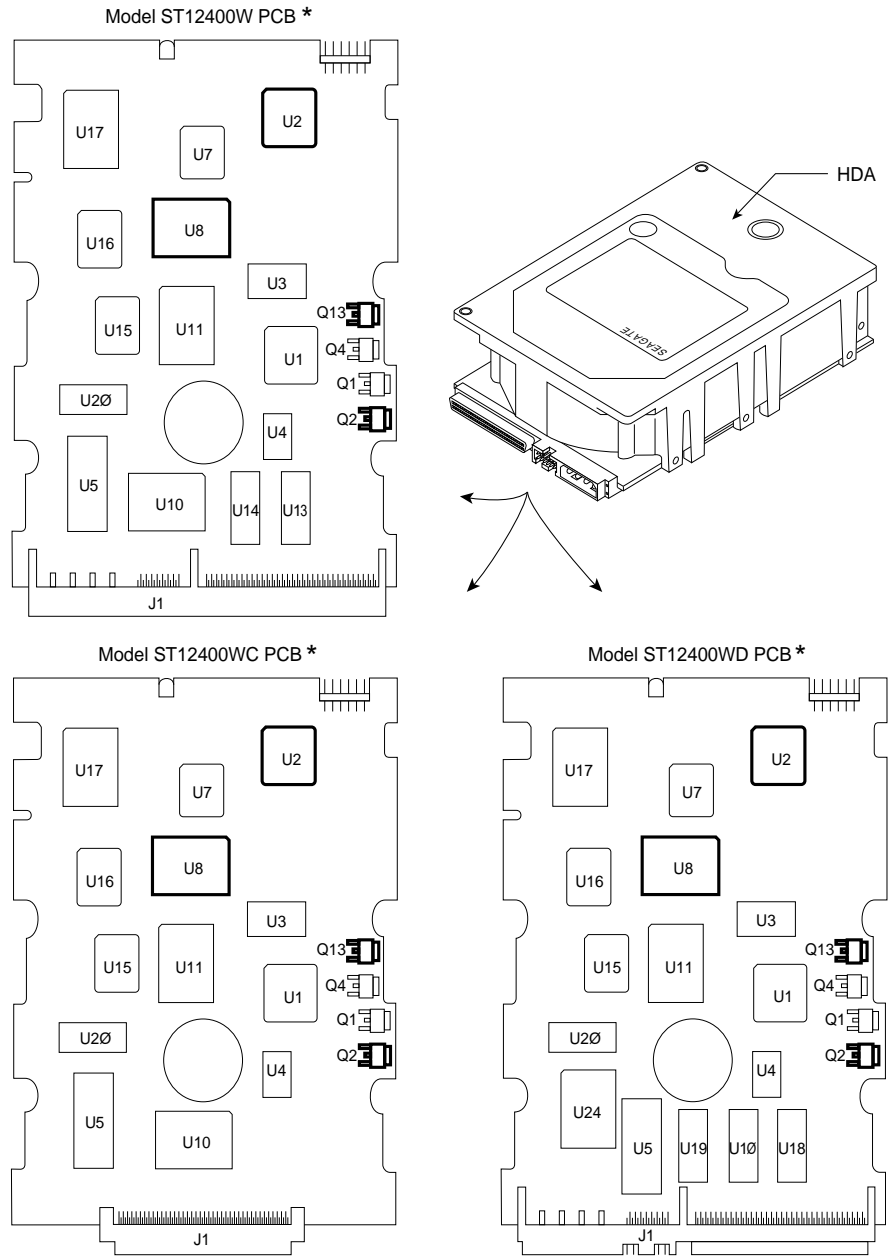

*Bottom side of PCB

Figure 7.4.1-1. Locations of components listed in Table 7.4.1-1

7.4.2 Relative humidity

The values below assume that no condensation on the drive occurs.

- a. Operating
8% to 80% relative humidity with a maximum gradient of 10% per hour.
- b. Non-Operating
5% to 95% relative humidity.

7.4.3 Effective altitude (Sea level reference)

- a. Operating
-1000 to +10,000 feet (-305 to +3048 metres)
- b. Non-Operating
-1000 to +40,000 feet (-305 to +12,210 metres)

7.4.4 Shock and vibration

Shock and vibration limits specified in this document are measured directly on the drive chassis. If the drive is installed in an enclosure to which the stated shock and/or vibration criteria is applied, resonance's may occur internally to the enclosure resulting in drive movement in excess of the stated limits. If this situation is apparent, it may be necessary to modify the enclosure to minimize drive movement.

The limits of shock and vibration defined within this document are specified with the drive mounted by any of the four methods shown in Figure 7.4.4-1.

7.4.4.1 Shock

- a. Operating

The drive, as installed for normal operation, shall operate error free while subjected to intermittent shock not exceeding 10 g's at a maximum duration of 11 ms (half sinewave). Shock may be applied in the X, Y, or Z axis.

- b. Nonoperating

The limits of nonoperating shock shall apply to all conditions of handling and transportation. This includes both isolated drives and integrated drives.

The drive subjected to nonrepetitive shock not exceeding 60 g's at a maximum duration of 11 ms (half sinewave) shall not exhibit device damage or performance degradation. Shock may be applied in the X, Y, or Z axis.

- c. Packaged

The drive as packaged in a single or multiple drive pack of gross weight 20 pounds (8.95 kg) or less by Seagate for general freight shipment shall withstand drop test from 42 inches (1070 mm) against a concrete floor or equivalent. For additional details refer to specification 30190-001 (under 100 lbs.) or 30191-001 (over 100 lbs.)

Package Size	Drop Height
600–1800 in ³ (9,832-29,502 cm ³)	48 in (121 cm)
>1800 in (>29,502 cm ³)	42 in (106 cm)

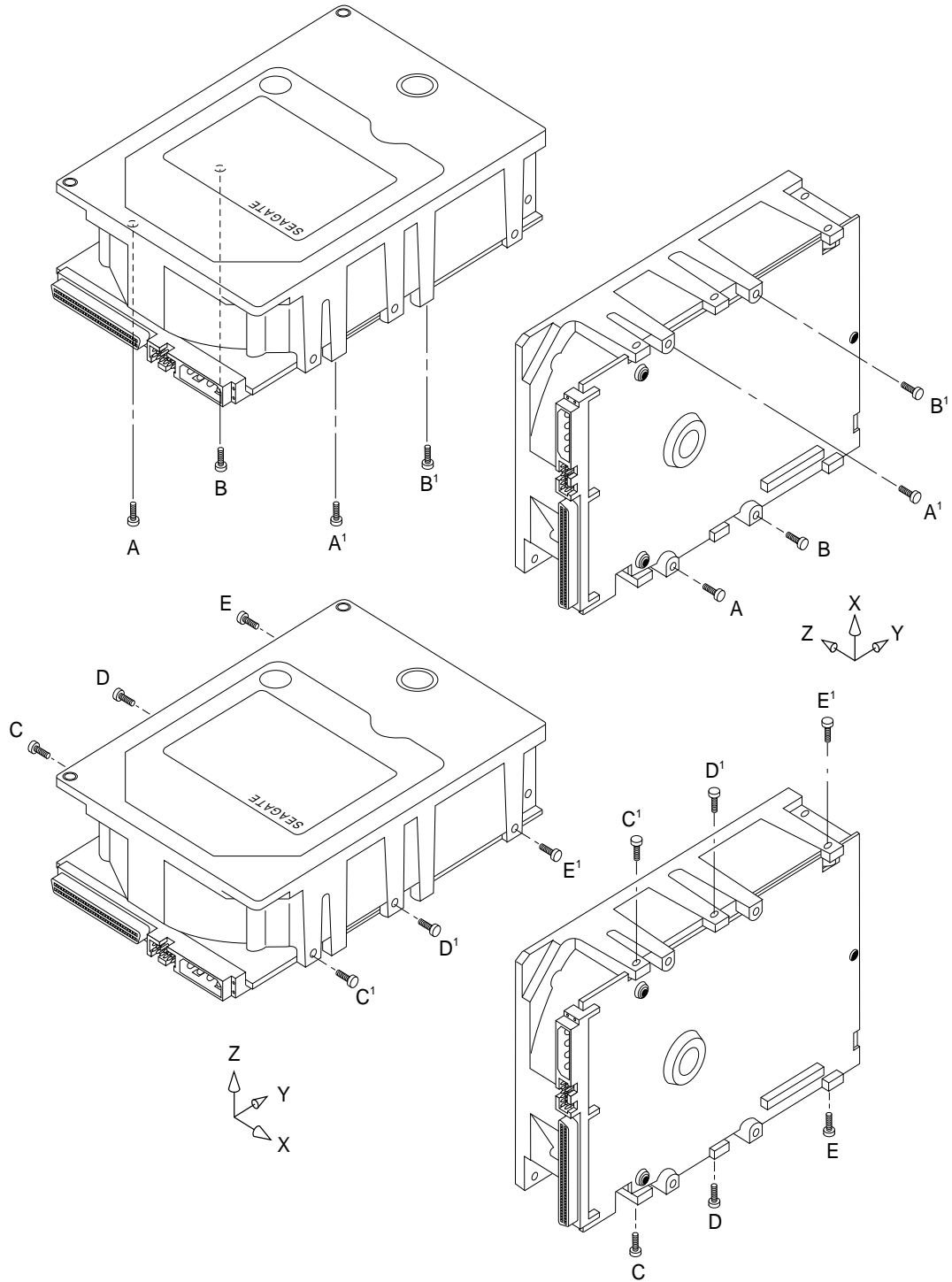

Figure 7.4.4-1. Recommended mounting

7.4.4.2 Vibration

a. Operating

The drive, as installed for normal operation, shall operate error free while subjected to continuous vibration not exceeding

5-22 Hz @ 0.040 inches (1.03 mm) displacement peak-to-peak

22-400 Hz @ 1.0 g

Vibration may be applied in the X, Y, or Z axis.

b. Nonoperating

The limits of nonoperating vibration shall apply to all conditions of handling and transportation. This includes both isolated drives and integrated drives.

The drive shall not incur physical damage or degraded performance as a result of continuous vibration not exceeding

5-22 Hz @ 0.081 inches (2.05 mm) displacement peak-to-peak

22-400 Hz @ 2.00 g's

Vibration may be applied in the X, Y, or Z axis.

7.4.5 Air cleanliness

The drive is designed to operate in a typical office environment with minimal environmental control.

7.5 Electromagnetic compatibility

7.5.1 Electromagnetic susceptibility

As a component assembly, the drive is not required to meet any susceptibility performance requirements. It is the responsibility of the system integrator to perform those tests required to ensure that equipment operating in the same system as the drive does not adversely affect the performance of the drive. See section 6.1.2, and see Table 7.2-1, DC Power Requirements.

7.6 Mechanical specifications

The following nominal dimensions are exclusive of the decorative front panel accessory. Refer to Figure 7.6-1 for detailed mounting configuration dimensions.

Height:	1.62 in	41.1 mm
Width:	4.00 in	101.6 mm
Depth:	5.74 in	145.8 mm
Weight:	1.9 pounds	0.84 kilograms

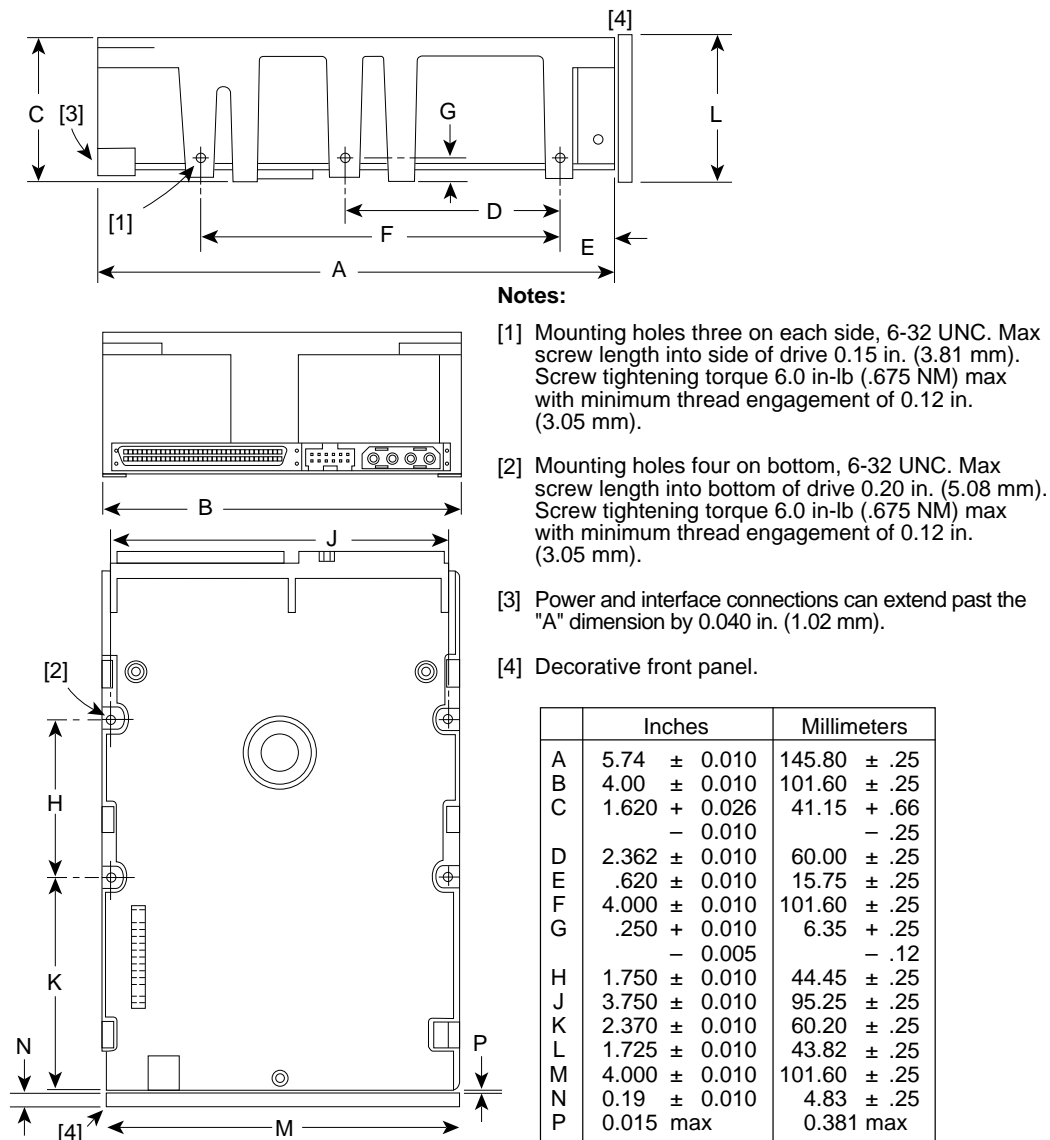

Figure 7.6-1a. Model ST12400W/WC mounting configuration dimensions

7.6.1 Drive Orientation

The balanced rotary arm actuator design of the drive allows it to be mounted in any orientation. All drive performance characterization, however, has been done with the drive in horizontal (discs level) and vertical (drive on its side) orientations, and these are the two preferred mounting orientations.

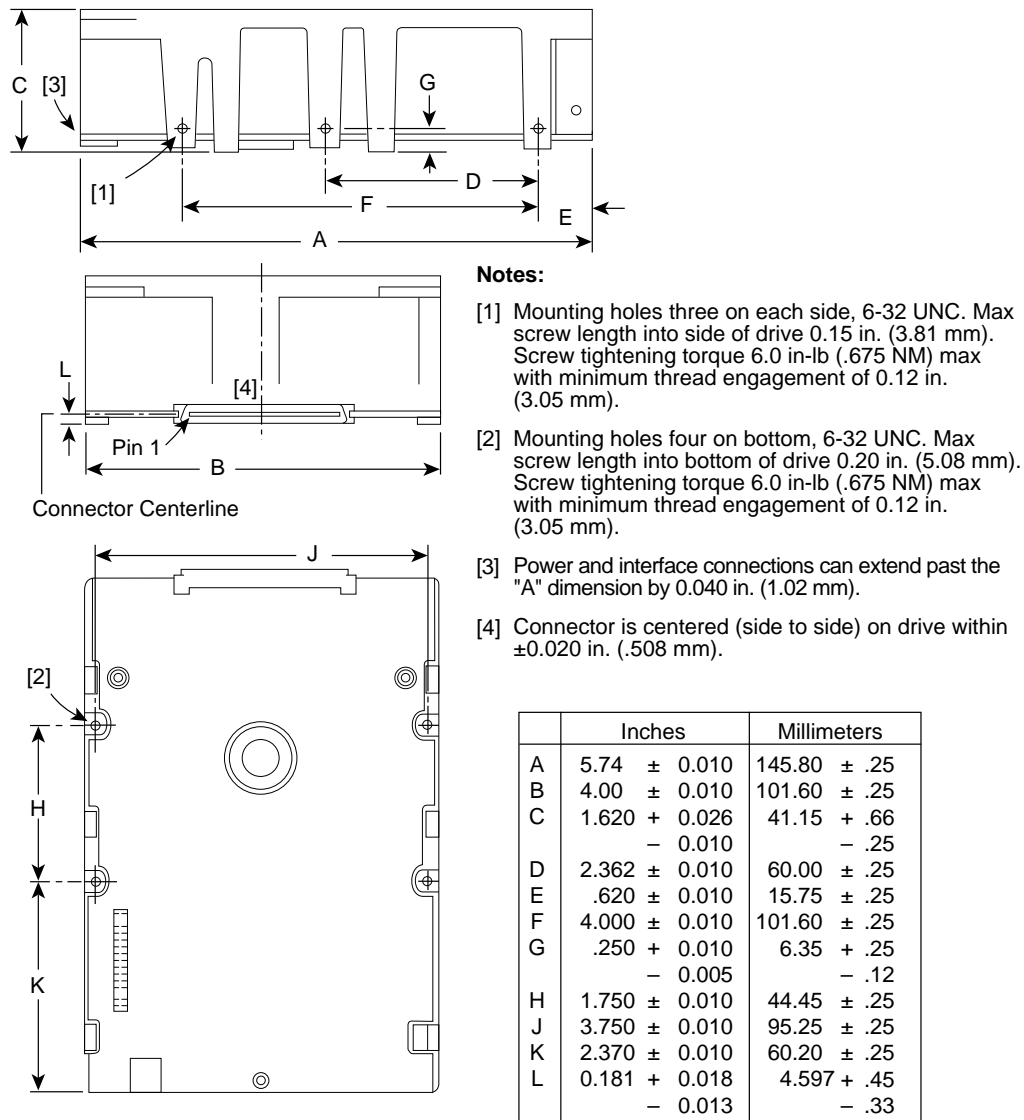

Figure 7.6-1b. Mounting configuration details for "WC" model drives

7.6.2 Cooling

Cabinet cooling must be designed by the customer so that the ambient temperature immediately surrounding the drive will not exceed temperature conditions specified in 7.4.1. Specific consideration should be given to make sure adequate air circulation is present around the PCBs to meet the requirements of 7.4.1.

7.6.3 Drive mounting

When mounting the drive using the bottom holes care must be taken to ensure that the drive is not physically distorted due to a stiff non-flat mounting surface. The allowable mounting surface stiffness is 80 lb/in (14.0 N/mm). The following equation and paragraph define the allowable mounting surface stiffness:

$$K \cdot x = 80 \text{ lb (14.0 N)}$$

where 'k' represents the mounting surface stiffness (units of lb/in or N/mm), and, 'x' represents the out-of-plane mounting surface distortion (units of inches or millimetres). The out-of-plane distortion ('x') is determined by defining a plane with three of the four mounting points fixed and evaluating the out-of-plane deflection of the fourth mounting point when a known force is applied to the fourth point.

8.0 Media characteristics

8.1 Media description

The media used on the drive has a diameter of approximately 95 mm (approximately 3.7 inches). The aluminum substrate is coated with a thin film magnetic material and overcoated with a proprietary protective layer for improved durability and environmental protection.

9.0 Defect and error management

The drive, as delivered, complies with this specification. The read error rate and specified storage capacity are not dependent upon use of defect management routines by the host (initiator).

Defect and error management in the SCSI system involves the drive internal defect/error management and SCSI systems error considerations (errors in communications between Initiator and the drive). Tools for use in designing a defect/error management plan are briefly outlined in this section, with references to other sections where further details are given.

9.1 Drive internal defects/errors

Identified defects are recorded on the drive defects list tracks (referred to as the primary or ETF defect list). These known defects are reallocated during the initial drive format operation at the factory. (See Format Unit command Section 5.2.1.2 in SCSI Interface Product Manual P/N 77738479). Data correction by ECC can be applied to recover data from additional flaws if they occur.

Details of the SCSI commands supported by the drive are described in SCSI Product Interface Manual, P/N 77738479. Also, more information on the drive Error Recovery philosophy is presented in Section 6 of the Interface Product Manual.

9.2 SCSI systems error considerations

Information on the reporting of operational errors or faults across the interface is given in SCSI Interface Product Manual. Message Protocol System is described in the SCSI Interface Product Manual. Several of the messages are used in the SCSI systems error management system. The Request Sense command returns information to the host about numerous kinds of errors or faults. The Receive Diagnostic Results reports the results of diagnostic operations performed by the drive.

Status returned by the drive to the Initiator is described in the SCSI Interface Manual. Status reporting plays a role in the SCSI systems error management and its use in that respect is described in sections where the various commands are discussed.

10.0 Option/configuration headers

10.1 Drive ID/option select header

Figure 10.1-1a shows a bottom view of the drive (PCB toward viewer) for the purpose of showing the drive ID and configuration option select jumper connectors for models ST12400W/WD. Figure 10.1-1c shows the jumper connectors for model ST12400WC. Figure 10.1-1b shows a rear view of the ST12400W/WD model drive for the purpose of showing J1-auxiliary which has a duplicate pin configuration and purpose of J6 (Figure 10.1-1a) on the rear of the drive. Both J1-auxiliary and J6 have pins for selecting drive ID and for connecting the synchronized spindle cable and the remote LED cable. Only one or the other should be used, although using both at the same time would not damage the drive. The notes ([1]-[9]) following the figures describe the functions of the various jumper positions on the three connectors J2, J1-auxiliary and J6. Suggested part number for the unusual J2 jumper is Molex 52747-0211 (Seagate P/N 77679052).

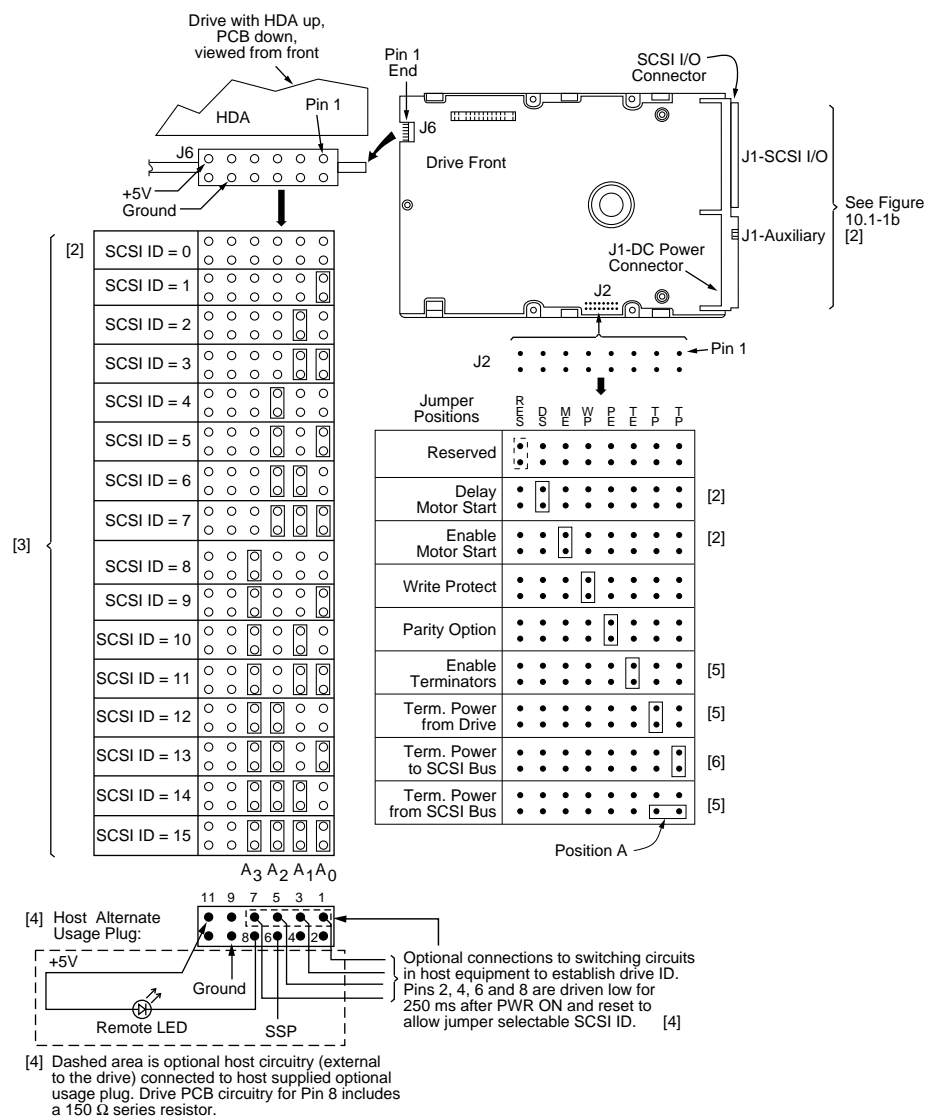

Figure 10.1-1a. ST12400W/WD family drive ID and option select header (Front and side header details)

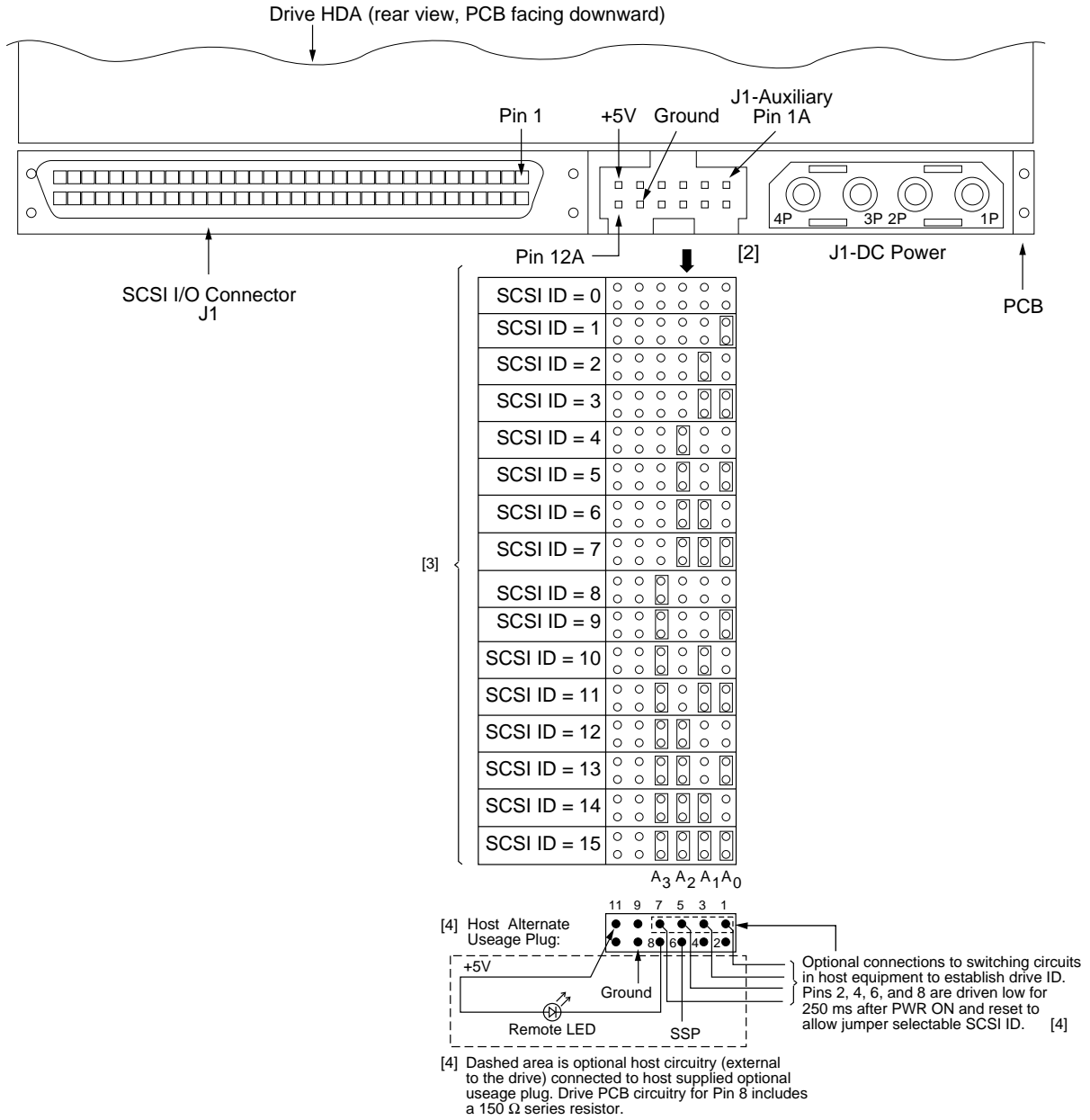

Figure 10.1-1b. ST12400W/WD family drive ID and option select header (Rear header details) (J1-auxiliary pins 1A-12A)

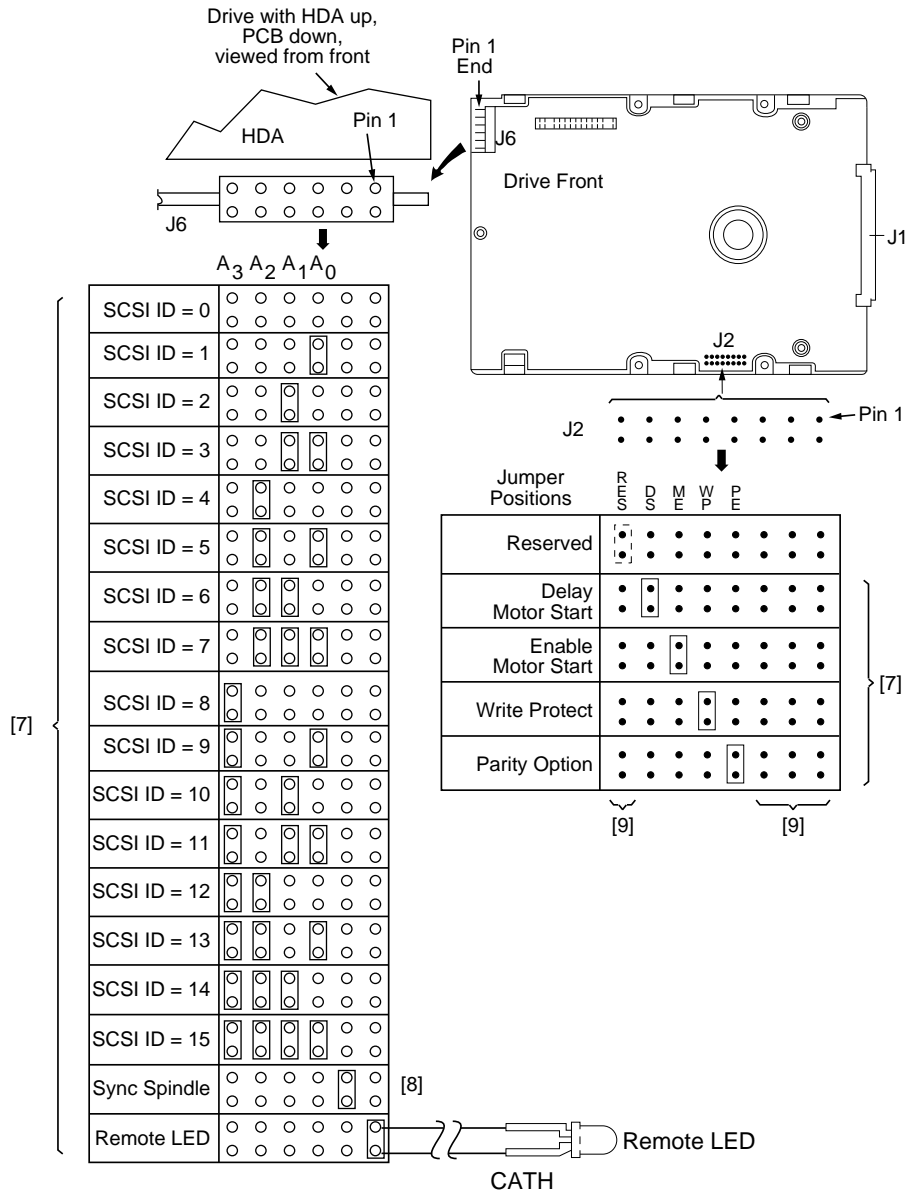

Figure 10.1-1c. ST12400WC family drive ID and option select header (front and side header details)

Notes for Figure 10.1-1a, 10.1-1b and 10.1-1c:

- [1] Notes explaining the functions of the various jumpers on jumper header connectors J2, J1-auxiliary and J6 are given below in left to right order of jumper position. The term “**default**” means as standard OEM units are configured when shipped from factory. “Off” means no jumper is installed; “On” means a jumper is installed. “Off” or “On” underlined is factory **default** condition.
- [2] The PCB on "WC" models does not have connector J1-auxiliary, but has a single 80 pin combined SCSI I/O and DC power connector instead of the pictured 68 pin SCSI I/O, J1-auxiliary and 4 pin DC power connectors. Included among the 80 pins are the SCSI ID, Motor Start and Delayed Motor Start select functions, and the synchronous spindle master sync signal (**REFIND+**) and the remote LED signals. Do not use J2 and J6 for these five functions if the host uses the ones included in the 80 pin connector. See Table 11.6.3-1c for a list of pin numbers vs. signals for the 80 pin connector.
- [3] Either jumper plugs in one of the patterns shown or external circuitry can be used to establish Drive ID. The drive uses headers J6 or J1-auxiliary for drive ID determination only during a 250 ms initialization period following power-on or after a drive reset. During this initialization period, the drive control logic connects pins 2, 4, 6 and 8 to ground and checks the logic state of pins 1, 3, 5 and 7. A ground on a pin 1, 3, 5, 7 indicates an asserted low state, while an open circuit, high impedance or +5 V indicates a negated high state. The drive user can install jumper plugs to connect pins 2, 4, 6 and 8 to pins 1, 3, 5 and 7, respectively, in the desired ID pattern. See figures 10.1-1a and 10.1-1b. The drive only connects ground to pins 2, 4, 6 and 8 during the 250 ms initialization period. The user may install a cable on J6 or J1-auxiliary in order to connect the drive ID pattern to pins 1, 3, 5 and 7 through some external switching circuit. The drive ID should be applied for at least the 250 ms period. During the remaining operational time of the drive, the drive does not poll pins 1, 3, 5 and 7 for drive ID, unless a reset occurs. See Note [4] for information on the use of pins 2, 4, 6 and 8 during non-initialization periods.
- [4] During non-initialization periods when the drive does not connect ground to pins 2, 4, 6 and 8, these pins can be used for non-drive ID functions. Therefore, instead of using jumper plugs on J1-auxiliary to establish drive ID, a cable can be connected to either J6 or J1-auxiliary to connect the drive activity (busy) LED as shown and make parallel connections of pins 1, 3, 5 and 7 to external drive ID switching or jumpering circuits. If connected as shown, pin 8 lights the drive busy LED when the drive connects ground to that pin. Connection can be made to pin 6 to conduct the synchronized spindle reference signal, REFIND+ to the host and to other Seagate disk drives. Spindle synchronization typically works effectively only if all drives connected through pin 6 are identical in make and model. During the 250 ms initialization period the LED lights and the REFIND+ signal goes to 0 V.

J6 can be used to establish drive ID using jumpers (or remote ID selector) and a cable can be plugged simultaneously to J1-auxiliary to connect to the drive activity (busy) LED and the synchronized spindle signal SSP. The vice-versa arrangement is possible also. Two separate drive ID determining locations should not be used, however.

continued from previous page

- [5] These jumper positions apply to model ST12400W only.
- [6] This jumper position applies to models ST12400W and ST12400WD only.
- [7] These signals are also on J1 (see Table 11.6.3-1c). The J2 and J6 jumper headers are not used if the J1 signals are used.
- [8] Drive is probably shipped with this jumper installed, but it should be removed if the system uses **REFIND+** on J1-37.
- [9] These jumper positions do not apply to "WC" models.

J2

Jumper

Installation Jumper Function Description

RES

Off/On Reserved. **Default** is no jumper installed.

DS ME

<u>Off</u>	<u>Off</u>	Spindle starts immediately after power up - Default setting.
Off	On	Drive spindle does not start until Start Unit command received from host.
On	Off	Spindle Startup is delayed by SCSI ID times 12 seconds after power is applied, i.e., drive 0 spindle starts immediately when DC power connected, drive 1 starts after 12 second delay, drive 2 starts after 24 second delay, etc.
On	On	Drive spindle starts when Start Unit command received from host. Delayed start feature is overridden and does not apply when ME jumper is installed.

WP

On	Entire drive is write protected.
<u>Off</u>	Drive is not write protected. Default is no WP jumper installed.

PE

<u>On</u>	Parity checking and parity error reporting by the drive is enabled. Default is PE jumper installed.
Off	Drive does not report result of parity checking to host.

continued from previous page

J2

Jumper

Installation Jumper Function Description

TE (ST12400W only)

On With the jumper installed, the On-board (non-removable) terminator circuits are enabled (connected to the I/O lines). **Default** is jumper installed.

Off Terminator circuits not connected to I/O lines.

TP TP

Off Off No terminator power is connected to drive terminators or SCSI bus I/O pin 26.

On Off Drive supplies its own terminator power only. Jumper on this position is factory **default**.

Off On Drive supplies power to I/O pin 26 of SCSI bus; none to internal terminators. When drives have differential I/O circuits, a jumper on the right **TP** position may be needed to power external terminators (see system documentation). The ST12400WD drive has differential I/O circuits which have no terminator circuits on the drive. The ST12400WC drive has no provisions for terminators and no provisions for terminator power in the 80 pin I/O connector. The **TP** jumpers do not apply to model ST12400WC.

On On Drive supplies terminator power to itself (internal connection) and to I/O pin 26 of SCSI bus. This is a legal jumper setting.

TP Position A

On This horizontally positioned jumper across the two **TP** positions nearest PCB edge, connects terminator power from SCSI bus I/O pin 26 to the drive's internal terminators (for Model ST12400W only).

Off See above explanations for **TP** jumpers.

J1-Auxiliary, J6

Jumper

Installation Jumper Function Description

A₃, A₂, A₁, A₀ Drive ID on SCSI Bus (J1-auxiliary or J6 may be used as the ID circuits are wired in parallel). The drive ID is binary coded positionwise i.e., jumper in position A₃ is drive ID 8, A₂ is drive ID 4, position A₁ is ID 2, position A₀ is ID 1 and no jumpers is ID 0. **Default** is ID = 0. Both J1-auxiliary and J6 should not be used at the same time, because at some future time when the ID is changed the user could fail to configure both J1-auxiliary and J6 the same. Model ST12400WC does not have J1-auxiliary.

continued from previous page

SSP Used only as a cable connection for the reference index signal (REFIND+) (J1-6A and J6 Pin 6, bottom) for sync spindle feature. J1-10A or J6-10 provides ground. See paragraphs 10.2, 5.7 for description of synchronized spindle operation. When no cable is connected, no jumpers should be installed. Factory **default** is **no** jumper installed. **If a jumper is installed between pins 5 and 6 it will erroneously enable Drive ID bit A2.**

BUSY LED See Note [4]

10.2 Synchronized spindles interface

The Synchronized Spindles Interface (SSI) allows several drives operating from the same host to operate their spindles at a synchronized rotational rate. Details of the electrical and physical interfaces follow in paragraphs 10.2.1 and 10.2.1.2 and 10.2.1.3. The system operation is described in paragraph 5.7. Spindle synchronization typically works effectively only if all drives connected to the REFIND+ signal are identical in make and model.

10.2.1 Electrical description

The electrical interface consists of one digital TTL reference index signal and ground. The reference index signal (REFIND+) is an output if the drive is configured as a master and is an input otherwise. The reference index signal is connected from drive to drive in a daisychain fashion as shown in Figure 5.7-1.

10.2.1.1 Drivers and receivers

Figure 10.2.1-1 shows a diagram of the driver/receiver circuit. The driver circuits have the following electrical specifications.

Negated (False): 0.0 V to +0.4 V @ I = - 48 mA (max)
 Asserted (True): +2.24 V to +5.25V @ I = +250 μ A

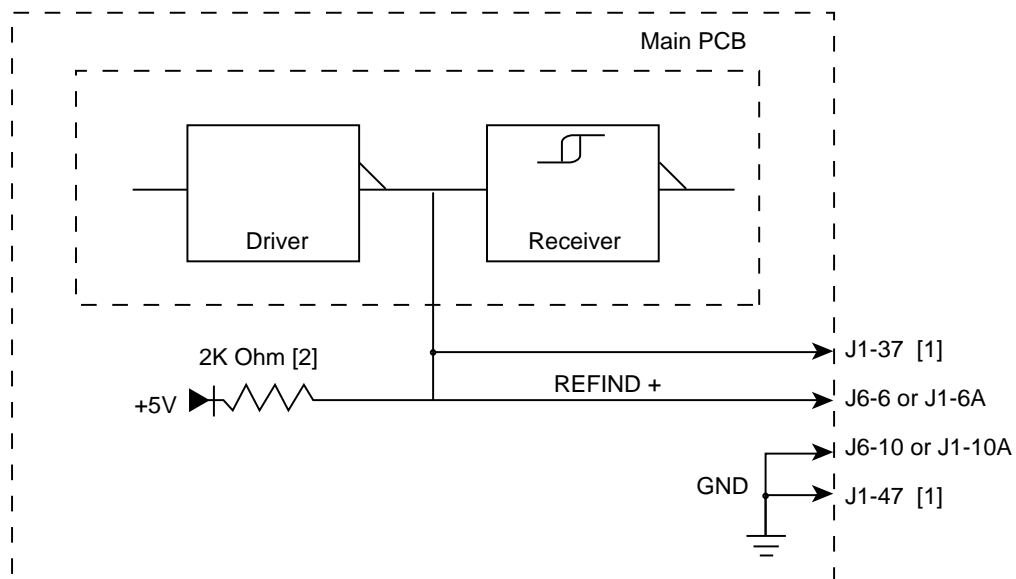

[1] This connection exists only on the ST12400WC model.

[2] See paragraph 10.2.1.2

Figure 10.2.1-1. SCSI reference index signal driver/receiver combination

10.2.1.2 Termination

The reference index signal (REFIND+) is terminated with a 2 K ohm resistor. Each drive has a termination resistor located on the Main PCB. The terminator resistor is not removable and is always in the circuit.

10.2.1.3 Physical interface

The dimensions of the connectors (J1-auxiliary and J6) mounted on the drive PCB to interconnect the drives is shown in Figure 10.2.1-2a. They are 12 pin, 6 jumper position gold header type connectors. Pins 6 and 10 are used for connecting the Reference Index signal from drive to drive, as shown in Figure 10.2.1-2a. Pin 6 is REFIND+ and Pin 10 is ground. Either J1-auxiliary or J6 may be used. On "WC" models REFIND+ is J6-6 and on J1-37.

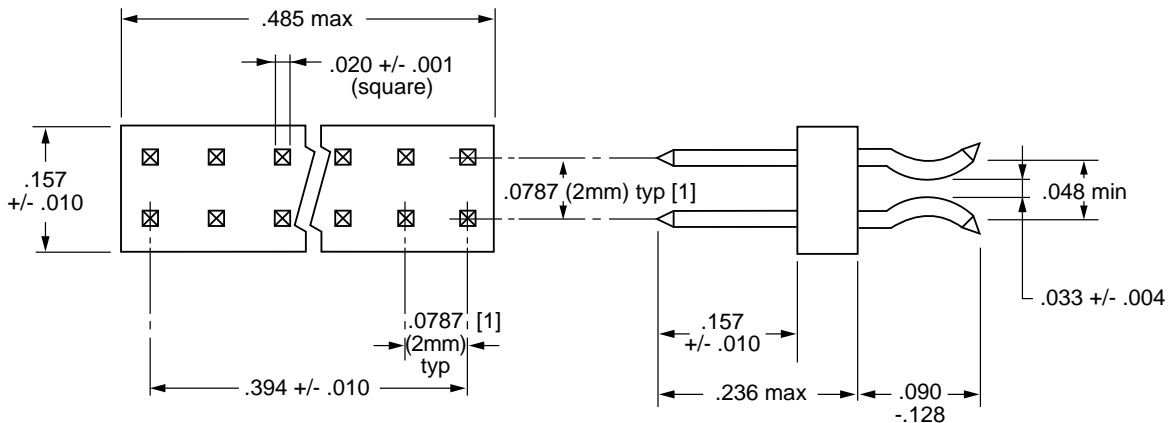

Figure 10.2.1-2a. Configuration select header specification for J6. (Connector at front end of PCB)

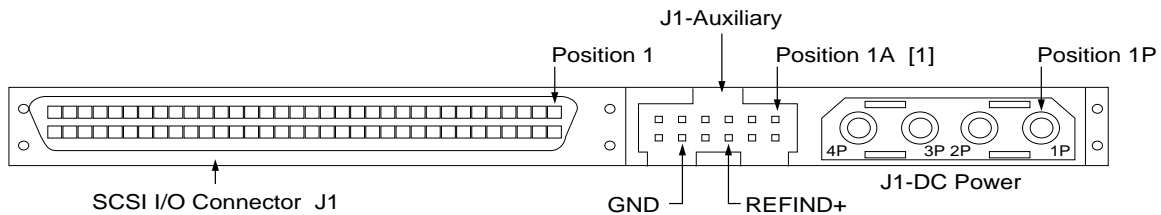

Figure 10.2.1-2b. Configuration select header for J1-auxiliary. (Connector at rear of model ST12400W/WD PCB)

[1] J1-auxiliary pins are on 0.0787 inch (2 mm) centers as shown in Figure 10.2.1-2a for J6.

10.3 Grounding

Signal ground (PCB) and HDA ground are connected together in the ST12400 wide drive and cannot be separated by the user. The equipment in which the drive is mounted is connected directly to the HDA and PCB with no electrically isolating shock mounts. If it is desired for the system chassis to not be connected to the HDA/PCB ground, the systems integrator or user must provide a nonconductive (electrically isolating) method of mounting the drive in the host equipment.

11.0 Interface requirements

11.1 General description

This section partially describes the interface requirements as implemented on the drives. The major portion of the interface requirements/implementation is described in the Seagate SCSI Interface Product Manual, P/N 77738479. This section has tables that give the ST12400W/WD/WC Family drives versions of the SCSI implementation described in the 77738479 document.

11.2 SCSI interface messages supported

Table 11.2-1 following lists the messages supported by the SCSI-1, SCSI-2 and SCSI-3 modes of the ST12400 Wide Family drives.

Table 11.2-1. SCSI messages supported by ST12400 wide family drives

Msg Code	Supported by:		Message Name
	SCSI-1	SCSI-2/SCSI-3	
01h [1]	Y	Y	Extended messages
06h	Y	Y	Abort
12h	N	Y	Continue I/O process
13h	N	Y	Target transfer disable
0Dh	Y	Y	Abort tag
0Ch	Y	Y	Bus device reset
0Eh	N	Y	Clear queue
00h	Y	Y	Command complete
04h	Y	Y	Disconnect
80h-FFh	Y	Y	Identify
23h	N	N	Ignore wide residue (two bytes)
0Fh	N	N	Initiate recovery
05h	Y	Y	Initiator detected error
0Ah	N	N	Linked command complete [2]
0Bh	N	N	Linked command complete with flag [2]
09h	Y	Y	Message parity error
07h	Y	Y	Message reject
[1]	N	N	Modify data pointer
08h	Y	Y	No operation
			Queue tag messages (two bytes)
21h	Y	Y	Head of queue tag
22h	Y	Y	Ordered queue tag
20h	Y	Y	Simple queue tag
10h	Y	N	Release recovery
03h	Y	Y	Restore pointers
02h	Y	Y	Save data pointer
[1]	Y	Y	Synchronous data transfer req.
11h	N	N	Terminate I/O process
[1]	N	Y	Wide data transfer request

[1] Extended messages (see P/N 77738479 SCSI-2/SCSI-3 Interface Product Manual).

[2] Customer Unique

11.3 SCSI interface commands supported

Table 11.3-1 following lists the SCSI interface commands that are supported in the SCSI-1, SCSI-2 and SCSI-3 modes of the drive. Hawk 2 Family (Wide bus) drives can be changed back and forth between SCSI-1 and SCSI-2 modes using the Change Definition Command. OEM standard drives are shipped set to operate in SCSI-2 mode.

Table 11.3-1. Commands supported by ST12400 wide family drives

Com'd Code	Supported by:		Command Name	
	SCSI-1	SCSI-2/SCSI-3		
00h	Y	Y	Test unit ready	
01h	Y	Y	Rezero unit	
03h	Y	Y	Request sense	
	Y	Y	Extended sense	
	Y	Y	Field pointer bytes	
	Y	Y	Actual retry count bytes	
	Y	Y	Deferred error supported	
	04h	Y	Y	Format unit [1]
	07h	Y	Y	Reassign blocks
08h	Y	Y	Read	
0Ah	Y	Y	Write	
0Bh	Y	Y	Seek	
12h	Y	Y	Inquiry	
	Y	Y	Vital product data page	
	Y	Y	Unit serial number page	
	Y	Y	Implemented operating def. page	
	Y	Y	Firmware numbers page	
	Y	Y	Date code page	
	Y	Y	Jumper settings page	
	15h	Y	Y	Mode select (same pages as mode sense command, see below)
16h	Y	Y	Reserve	
	Y	Y	3rd parity reserve	
	N	N	Extent reservation	
17h	Y	Y	Release	
18h	N	N	Copy	
1Ah	Y	Y	Mode sense	
	Y	Y	Unit attention page (00h)	
	Y	Y	Byte 2 bit 4 (unit attn bit)	
	Y	Y	Byte 2 bit 5 (DEID bit)	
	Y	Y	Error recovery page (01h)	
	Y	Y	Disconnect/reconnect Control page (02h)	
	Y	Y	Format page (03h)	
	Y	Y	Rigid disc drive geometry page (04h)	
	N	Y	Verify error recovery page (07h)	
	Y	Y	Caching parameters page (08h)	
	N	Y	Control mode page (0Ah)	
	N	Y	Notch and Partition Page (0C) (Media Zones)	

[1] ST12400 wide family can format to any even number of bytes per sector from 180 to 4096.

continued from previous page

Com'd Code	Supported by:		Command Name
	SCSI-1	SCSI-2/SCSI-3	
1Bh	Y	Y	Start unit/stop unit (spindle ceases rotating)
1Ch	Y	Y	Receive diagnostic results
	Y	Y	Supported diagnostics pages
	Y	Y	Translate page
	Y	Y	Translate page
1Dh	Y	Y	Send diagnostics page
	Y	Y	Supported diagnostics pages
	Y	Y	Translate page
25h	Y	Y	Read capacity
28h	Y	Y	Read extended
2Ah	Y	Y	Write extended
2Bh	Y	Y	Seek extended
2Eh	Y	Y	Write and verify
2Fh	Y	Y	Verify
30h	N	N	Search data high
31h	N	N	Search data equal
32h	N	N	Search data low
33h	N	N	Set limits
34h	N	N	Prefetch
35h	N	Y	Synchronize cache
36h	N	N	Lock-unlock-cache
37h	Y	Y	Read defect data
39h	N	N	Compare
3Ah	N	N	Copy and verify
3Bh	Y	Y	Write buffer
3Ch	Y	Y	Read buffer
3Eh	Y	Y	Read long
3Fh	Y	Y	Write long
40h	Y	Y	Change definition
41h	N	Y	Write same
42-4Bh	N	N	Not used
4Ch	Y	Y	Log select
4Dh	Y	Y	Log sense
4E-54	N	N	Not used
55h	Y	Y	Mode select (10)
56-59	N	N	Not used
5Ah	Y	Y	Mode sense (10)
5B-5F	N	N	Not used
60-BFh	N	N	Not used
C0-DFh	N	N	Not used
EO-FFh	N	N	Not used

11.3.1 Inquiry data

11.3.1.1 Standard Inquiry data

Table 11.3.1-1 following lists the Inquiry command data that the drive should return to the initiator per the format given in the SCSI-2/SCSI-3 Interface Product Manual (P/N 77738479).

Table 11.3.1-1. ST12400ND wide family drive standard inquiry data

BYTES	DATA (HEX)
0-15	00 00 ** *** 8F 00 () () 53 45 41 47 41 54 45 20
16-31	53 54 [31][32][34][30][30][57][44]20 20 20 20 20 20 20
32-47	R# R# R# R# S# S# S# S# S# S# S# S# 00 00 00 00
48-63	00 00 00 00 00 00 00 00 00 00 00 00 00 00 00 00
64-79	00 00 00 00 00 00 00 00 00 00 00 00 00 00 00 00
80-95	00 00 00 00 00 00 00 00 00 00 00 00 00 00 00 00
96-111	00 43 6F 70 79 72 69 67 68 74 20 28 63 29 20 31*
112-127	39* 39* 32* 20 53 65 61 67 61 74 65 20 41 6C 6C 20
128-143	72 69 67 68 74 73 20 72 65 73 65 72 76 65 64 20
144-148	D# D# D# D#

*Copyright Year - changes with actual year.

Notes.

- ** 01 means SCSI-1 implemented;
02 means SCSI-2 implemented. Hawk 2 Family (Wide bus) drives can be changed between these two configurations. Default is 02.
- *** 01 means response data is in SCSI-1 format and has compatibility with Common Command Set data.
02 means response data is in SCSI-2 format. The drive can be changed between these two configurations. Default is 02. Though the drive supports some "SCSI-3" features, there are no provisions to indicate this in the Inquiry response data.
- () Inquiry data reports 01 32 if 16 bit wide address and data bus is used; 00 12 if 8 bit wide address and data bus is used.
- R# Four ASCII digits representing the last four digits of the product Firmware Release number. This information is also given in the Vital Product Data page C0h, together with servo RAM and ROM release numbers.
- S# Eight ASCII digits representing the eight digits of the product serial number.
- D# Four ASCII digits representing the firmware distribution diskette serial number.
- [] Bytes 18 through 24 will reflect model of drive. Shown here are hex values for ASCII codes representing "ST12400WD". Byte 24 is 43 for model ST12400WC.

11.3.1.2 Inquiry Vital Product data

Instead of the standard Inquiry data shown in Table 11.3.1-1, the initiator can request several Vital Product Data pages by setting the Inquiry command EVDP bit to one. The SCSI-2/SCSI-3, Version 2 Interface Product Manual P/N 77738479, Section 5.1.1.3.1 lists the Vital Product Data pages supported and describes their formats. A separate Inquiry command must be sent to the drive for each Vital Product Data page the initiator wants the drive to send back.

11.3.2 Mode Sense data

The Mode Sense command provides a means for the drive to report its operating parameters to the initiator. The drive maintains four sets of Mode parameters, Default values, Saved values, Current values and Changeable values.

Default values are hard coded in the drive firmware that is stored in flash E-PROM nonvolatile memory on the drive PCB. Default values can be changed only by downloading new firmware into the flash E-PROM. An initiator can request and receive from the drive a list of Default values and use those in a Mode Select command to set up new Current and Saved values.

Saved values are stored on the disk media using a Mode Select command. Only parameter values that are allowed to be changed can be changed by this method. See “Changeable values” defined below. Parameters in the Saved values list that are not changeable by the Mode Select command get their values from the Default values storage.

Current values are volatile values currently being used by the drive to control its operation. A Mode Select command can be used to change these values (only those that are changeable). Originally, they are installed from Saved or Default values after a power on reset, hard reset, or Bus Device Reset message.

Changeable values form a bit mask, stored in nonvolatile memory, that dictates which of the Current values and Saved values can be changed by a Mode Select command. A “one” allows a change to a corresponding bit; a “zero” allows no change. For example, in Table 11.3.2-1a refer to Mode page 01, in the first row entitled “CHG”. These are hex numbers representing the changeable values for Mode page 01. Note in columns 1 and 2 (bytes 00 and 01), there is 00h, which indicates that in bytes 00 and 01 none of the bits are changeable. Note also that bytes 04, 05, 06 and 07 are not changeable, because those fields are all zeros. In bytes 02, hex value FF equates to the binary pattern 1111 1111. If there were a zero in any bit position in the field, it would mean that bit is not changeable. However, bits 7 - 0 are changeable, because those bits are all ones. In this particular case, it indicates 8 error recovery control bits are all changeable. FF in column 4 indicates all bits in byte 3 are changeable.

The Changeable values list can only be changed by downloading new firmware into the flash E-PROM.

On drives requiring unique Saved values, the required unique Saved values are stored into the Saved values storage location on the media prior to shipping the drive. Some drives may have unique firmware with unique Default values also.

On standard OEM drives the Saved values are taken from the Default values list and stored into the Saved values storage location on the media prior to shipping.

When a drive is powered up, it takes Saved values from the media and stores them to the Current values storage in volatile memory. It is not possible to change the Current values (or the saved values) with a Mode Select command before the drive is up to speed and is “ready.” An attempt to do so results in a “Check Condition” status being returned.

11.4 SCSI Bus Conditions and Miscellaneous Features Supported

Asynchronous SCSI bus conditions supported by the drive are listed in Table 11.4-1. These conditions cause the SCSI device to perform certain actions and can alter the phase sequence. Other miscellaneous operating features supported are also listed here.

Table 11.4-1. SCSI bus conditions and other misc. features

Condition/Feature Supported by:

SCSI-1	SCSI-2/SCSI-3	Conditions or Feature
Y	Y	Attention Condition
Y	Y	Reset Condition
Y	Y	Contingent Allegiance Condition
N	N	Asynchronous Event Notification
Y	Y	Arbitrating System
Y	Y	Disconnect/Reconnect
Y	Y	Asynchronous Data Transfer
Y	Y	Synchronous Data Transfer
Y	Y	Synchronized (locked) Spindle Operation
Y	Y	Differential Interface Circuits available
Y	Y	Segmented Caching
N	N	Zero Latency Read
Y	Y	Queue tagging (up to 64 Que tags supported)
Y	Y	Deferred Error Handling
Y	Y	Parameter Rounding
Y	N	Reporting actual retry count in Extended Sense bytes 15, 16 and 17.
Y	Y	Adaptive Caching (available only on some drives)
Y	Y	SMP = 1 in Mode Select command needed to save RPL and Rotational Offset bytes (in Table 5.2.1-25 of Vol. II).
Y	Y	Immediate status for Start/Stop command
N	N	Immediate status for Format unit and Synchronize Cache commands
N	N	Format Progress Indication
[1]	[1]	Flag and Link bits in control byte supported
SCSI-1	SCSI-2/SCSI-3	Status Supported
Y	Y	Good
Y	Y	Check Condition
Y	Y	Condition Met/Good
Y	Y	Busy
[1]	[1]	Intermediate/Good
Y	Y	Intermediate/Condition Met/Good
Y	Y	Reservation Conflict
Y	Y	Queue Full

Notes:

[1] Option supported only if customer requests.

11.5 Synchronous data transfer**11.5.1 Synchronous data transfer periods supported**

Table 11.5-1 and 11.5-2 list Synchronous Data transfer periods supported by the drive. The data transfer period to be used by the drive and the initiator is established by an exchange of messages during the Message Phase of operation. See the section on message protocol in the SCSI Interface manual.*

Table 11.5-1. Synchronous data transfer periods

M (Decimal)	Transfer Period (M times 4 nanoseconds)
25	100
31	125
37	150
50	200
62	250
75	300
87	350
100	400

11.5.2 REQ/ACK offset

The maximum REQ/ACK offset supported by the ST12400 wide family is 15 (0Fh).

*SCSI Interface Product Manual, P/N 77738479

11.6 Physical interface

Figure 11.6-1 shows the locations of the physical interface components for the drive. Shown are the locations of the D.C. power connector, the SCSI interface connector, the I/O line terminators, and the drive select and option select header.

Details of the physical, electrical and logical characteristics are given in paragraphs following, while the SCSI operational aspects of Seagate drive interfaces are given in the Seagate SCSI Interface Product Manual, P/N 77738479.

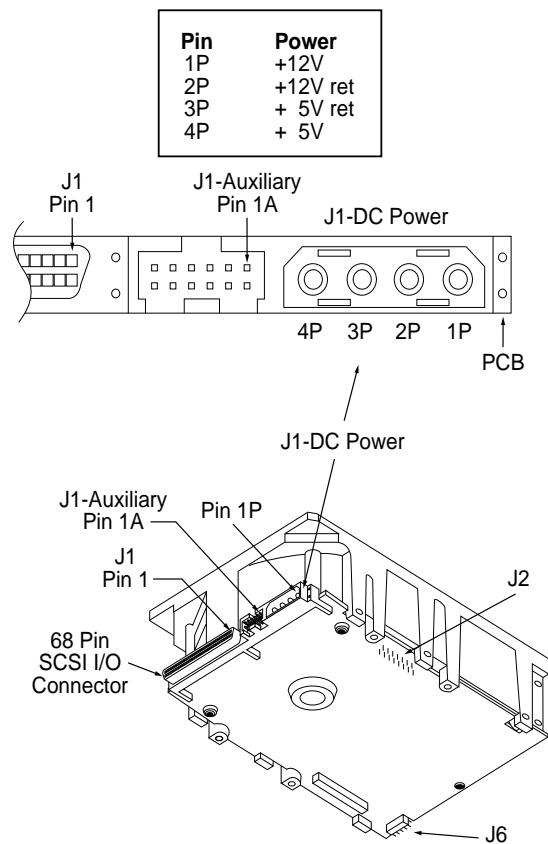

Figure 11.6-1a. ST12400W/WD family drive physical interface

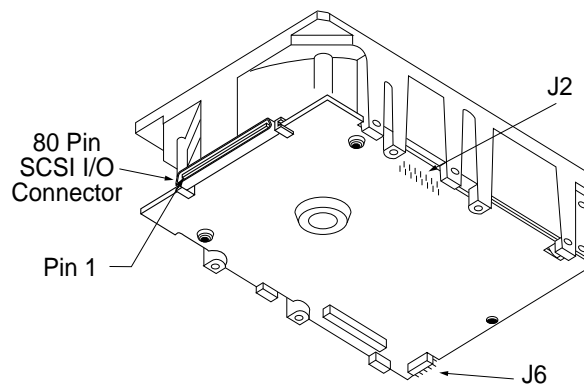

Figure 11.6-1b. Model ST12400WC physical interface (80 pin I/O and DC power connector)

11.6.1 DC cable and connector

The model ST12400W/WD drive receives DC power through a 4 pin connector mounted at the rear of the main PCB (see Figure 11.6.3-1a). Recommended part numbers of the mating connector are listed below, but equivalent parts may be used (see Table 11.6.1-1).

Table 11.6.1-1. Mating connector parts

Type of cable	Connector	Contacts (20-14 AWG)
14 AWG	AMP 1-480424-0	AMP 60619-4 (Loose Piece) AMP 61117-4 (Strip)

The model ST12400WC requires no extra DC power cable since both DC power and SCSI I/O signals are all in the single 80 pin connector. See Table 11.6.3-1b for pin assignments.

11.6.2 Physical characteristics

This section defines the connectors, cables, signals, terminators and bus timing needed to implement SCSI.

11.6.2.1 Physical description

The model W and WD drives may be daisychained together or with other compatible SCSI devices using a common cable. Both ends of the cable must be terminated. Model ST12400 wide drives do not have on-board terminator circuits. The ST12400WD drive implements differential drivers and receivers. The model ST12400W/WC drive implements single ended drivers and receivers. All signals are common between all SCSI devices. The drive may be daisychained only with SCSI devices having the same type drivers and receivers. Devices having single ended interface circuits cannot be on the same daisychain with devices having differential interface circuit. A maximum of 16 SCSI devices (including the Host) may be daisychained together. The SCSI Devices at both ends of the daisychain are to be terminated. Intermediate SCSI devices shall not be terminated (see Figure 11.6.3-1). Remove or disable (whichever is applicable) the terminators. Do not remove the terminator power source selector jumper **TP** (See Figure 10.1-1 and accompanying notes).

"NC" model drives plug into PCB or bulkhead connectors in the Host. They may be connected in a daisy-chain by the host backplane wiring or PCB circuit runs that have adequate DC current carrying capacity to support the number of drives plugged into the PCB or bulkhead connectors. A single 80 pin I/O connector cannot support the DC current needs of several drives, so no daisy-chain cables should be used. A single drive connected via a cable to a host 80 pin I/O connector is not recommended.

11.6.2.2 Cable requirements ("W" and "WD" models only)

11.6.2.2.1 Single ended I/O circuits ("W" models)

The maximum total cable length for use with "W" model drives (single ended I/O driver and receiver circuits) shall be 6 metres (19.7 ft.) when operating at line data transfer rates of 5 MBytes/sec or less, and 3 metres (9.85 ft.) when operating at transfer rates greater than 5 Mbytes/sec (FAST SCSI). A stub length of no more than 0.1 metre (0.33 ft.) is allowed off the mainline interconnection with any connected equipment. An ideal impedance match with cable terminators implies a cable characteristic impedance of 132 ohms (see 11.6.2.2.3). Model ST12400W/WC single ended I/O pin assignments are shown in Table 11.6.3-1a.

11.6.2.2.2 Differential I/O circuits ("WD" models)

The maximum total cable length for use with drives having differential I/O drivers and receiver circuits shall be 25 metres (82 ft.). A stub length of no more than 0.2 metre (0.66 ft.) is allowed off the mainline interconnection with any connected equipment. An ideal impedance match with cable terminators implies a cable characteristic impedance of 122 ohms. Model ST12400WD differential I/O pin assignments are shown in Table 11.6.3-1b.

11.6.2.2.3 General cable characteristics

In general, cables having the characteristic impedance's given above are not available; however, impedance's that are somewhat lower are satisfactory. A characteristic impedance of 100 ohm \pm 10% is recommended for unshielded flat or twisted pair ribbon cable. However, most available cables have a somewhat lower characteristic impedance. To minimize discontinuities and signal reflections, cables of different impedance's should not be used in the same bus. Implementations may require tradeoffs in shielding effectiveness, cable length, the number of loads, transfer rates, and cost to achieve satisfactory system operation. If shielded and unshielded cables are mixed within the same SCSI bus, the effect of impedance mismatch must be carefully considered. Proper impedance matching is especially important in order to maintain adequate margin at FAST SCSI transfer rates.

Cable for "W/WD" model drives

Only nonshielded cable is applicable. A 68 conductor flat cable or two, 34 conductor cables shall be used. Conductors should be on 50 (1.27 mm) mil centers to be used with connector listed in 11.6.3.1. A minimum conductor size of 28 AWG should be used to minimize noise effects.

Suggested nonshielded flat cable part numbers are:

Flat cable - 35M-3365-68 Twisted pair - Spectra Twist in flat 455-248-68

Equivalent parts may be used.

Cables for "WC" drive models

The 80 pin connector option is intended for use on drives that plug directly into a wall or bracket mounted connector in the host equipment. Cable mounted connectors would not be used in such a case. Installations with cable mounted connectors are not recommended.

11.6.3 Connector requirements

11.6.3.1 Mating connectors for model ST12400W/WD

The nonshielded cable connector shall be a 68 conductor connector consisting of two rows of 34 male contacts with adjacent contacts 1.27 mm (0.050 inch) apart.

Recommended Mating Connector Part Numbers for above flat cable are:

Closed end (for cable ends)	Amp Model 749925-5	(50 mil conductor centers for 28 or 30 AWG wire) This connector can only be used on cable ends.
Open end	Amplimite 88-5870-294-5	W/O Strain Relief, (25 mil conductor centers, 30 AWG wire). Use either on cable ends or in cable middle section for daisychain installations.

The disc drive device connector is a nonshielded 68 conductor connector consisting of two rows of 34 female pins with adjacent pins 1.27 mm (0.050 inches) apart. The connector is keyed by means of its shape (see Figure 11.6.3-1a).

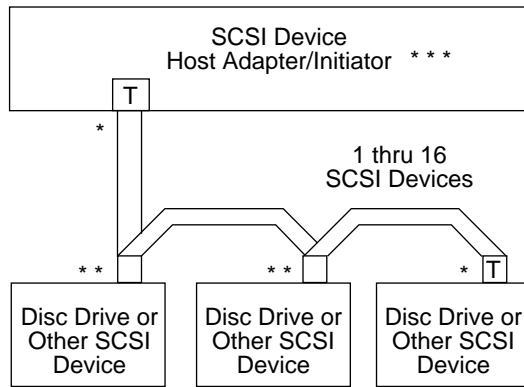

VIEW B

T indicates termination required

Total Interface cable length must not exceed that specified in paragraph 11.6.2. (Including host adapter/initiator).

* Closed end type connector used.

** Open end type (in-line application) connector used

*** Host need not be on the end of the daisychain. Another device can be on the end with the terminator. The host can be anywhere in the daisychain, having no terminator.

Figure 11.6.3.-1. Interface cabling

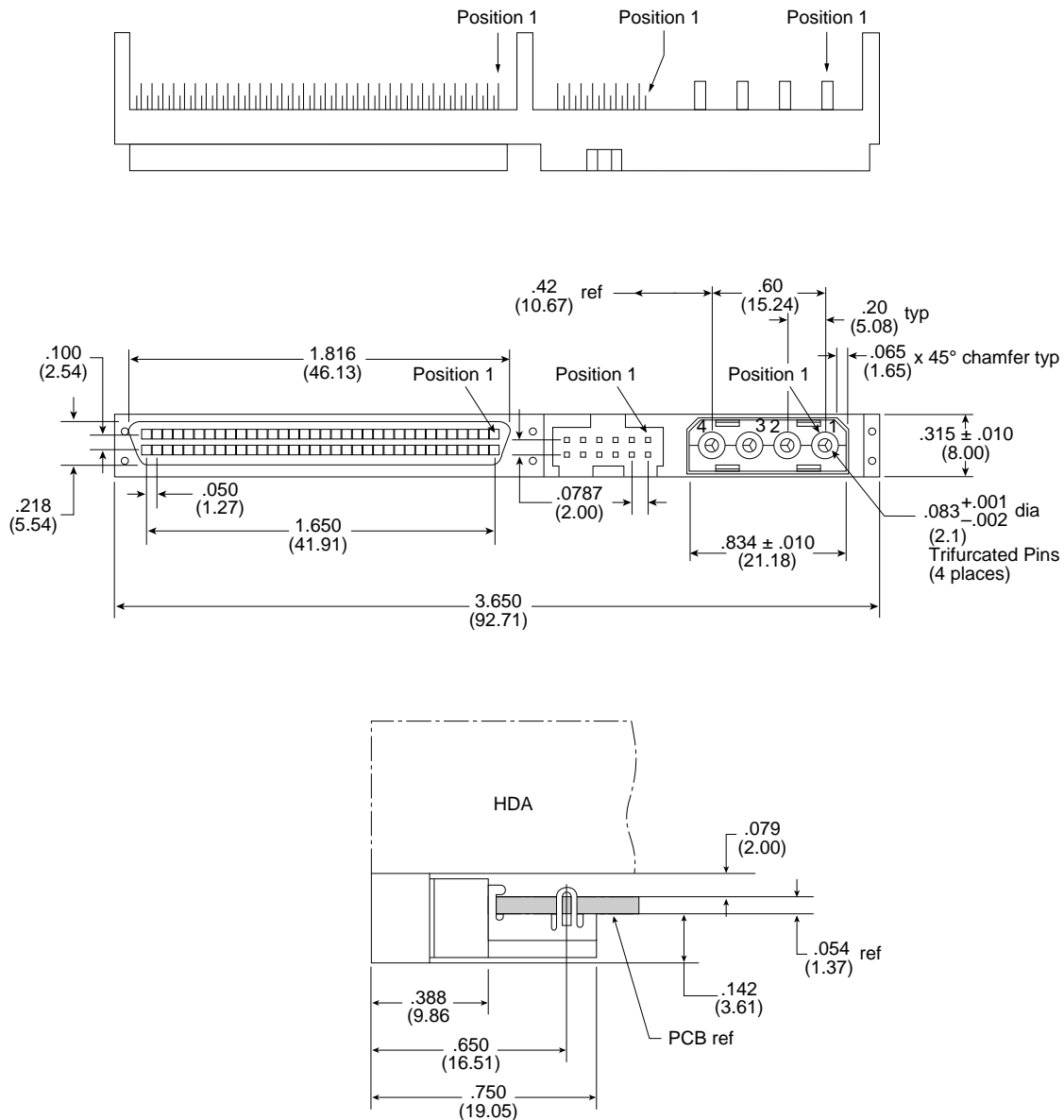

Figure 11.6.3-1a. Non shielded SCSI device connector for model ST12400W/WD

11.6.3.2 Mating connectors for "WC" models

The non-shielded connector shall be an 80 conductor connector consisting of two rows of 40 contacts with adjacent contacts 50 mils (1.27 mm) apart. The connector is keyed by its shape. The characteristics of the drive's PCB mounted connector are shown in Figure 11.6.3-1b.

11.6.3.3 J2 Jumper plug part number

Option select header connector J2 on the PCB (see Figure 10.1-1) uses an unusual type of jumper, its part number is given here for reference:

Molex 52747-0211 (Seagate P/N 77670952).

Recommended PCB or bulkhead mounted connectors are:

Straight-in connector (most commonly used):

Seagate P/N: 77678703
 Amp US P/N: 2-557103-1
 Amp Japan P/N: 5-175475-9

Right angle to PCB connector:

Seagate P/N: 77678559
 Amp US P/N: 2-557101-1
 Amp Japan P/N: 5-175474-9

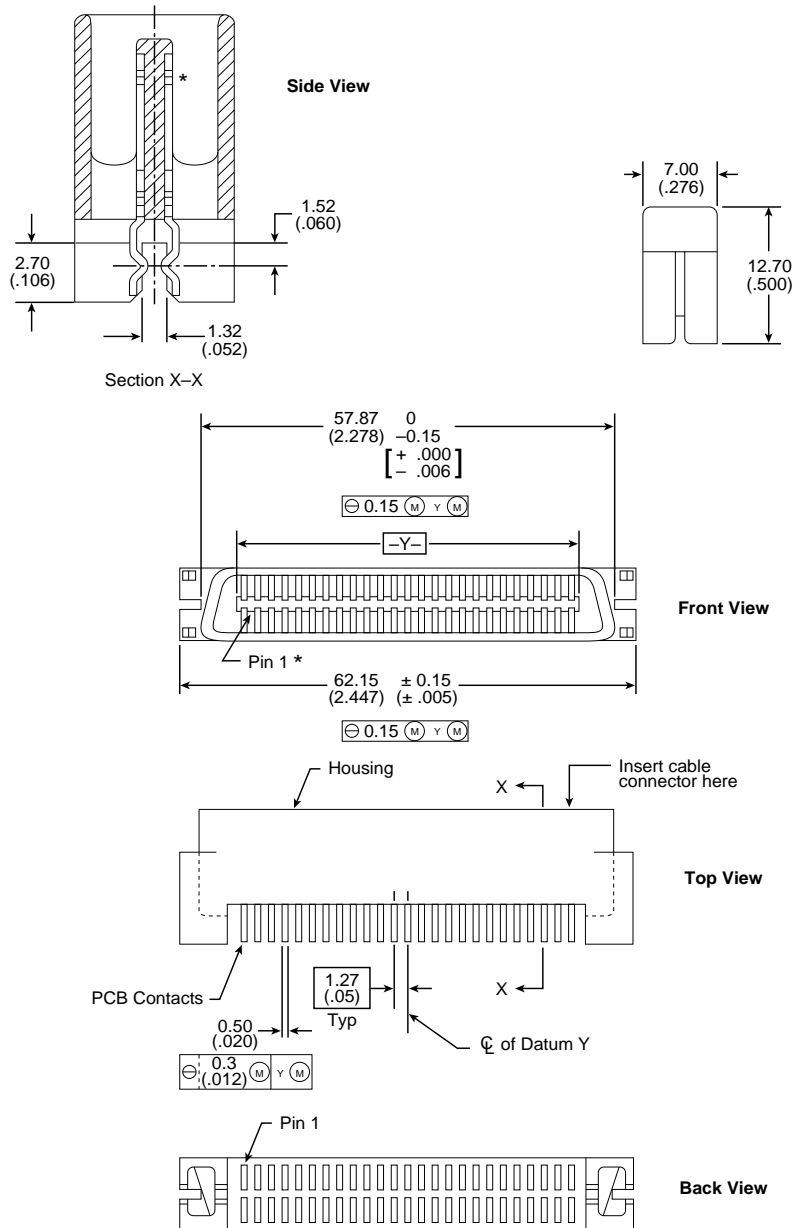

* Contacts are recessed along the center strip (see side view).

Figure 11.6.3-1b. Non-shielded 80 pin I/O and DC power connector for model ST12400WC

Table 11.6.3-1a. ST12400WD differential cable pin assignments (nonshielded connector)

Note. The minus sign next to the signals indicates asserted state is the low voltage of the two levels used for logic signals

Connector Signal Name*	Cable Contact Number	Connector Conductor Number	Contract Number	Signal Name	
+DB(12)	1	1	2	35	-DB(12)
+DB(13)	2	3	4	36	-DB(13)
+DB(14)	3	5	6	37	-DB(14)
+DB(15)	4	7	8	38	-DB(15)
+DB(P1)	5	9	10	39	-DB(P1)
Ground	6	11	12	40	Ground
+DB(0)	7	13	14	41	-DB(0)
+DB(1)	8	15	16	42	-DB(1)
+DB(2)	9	17	18	43	-DB(2)
+DB(3)	10	19	20	44	-DB(3)
+DB(4)	11	21	22	45	-DB(4)
+DB(5)	12	23	24	46	-DB(5)
+DB(6)	13	25	26	47	-DB(6)
+DB(7)	14	27	28	48	-DB(7)
+DB(P)	15	29	30	49	-DB(P)
DIFFSENS	16	31	32	50	Ground
TermPwr	17	33	34	51	TermPwr
TermPwr	18	35	36	52	TermPwr
Reserved	19	37	38	53	Reserved
+ATN	20	39	40	54	-ATN
Ground	21	41	42	55	Ground
+BSY	22	43	44	56	-BSY
+ACK	23	45	46	57	-ACK
+RST	24	47	48	58	-RST
+MSG	25	49	50	59	-MSG
+SEL	26	51	52	60	-SEL
+C/D	27	53	54	61	-C/D
+REQ	28	55	56	62	-REQ
+I/O	29	57	58	63	-I/O
Ground	30	59	60	64	Ground
+DB(8)	31	61	62	65	-DB(8)
+DB(9)	32	63	64	66	-DB(9)
+DB(10)	33	65	66	67	-DB(10)
+DB(11)	34	67	68	68	-DB(11)

Notes. 1. The conductor number refers to the conductor position when using 0.025- inch centerline flat ribbon cable. Other cable types may be used to implement equivalent contact assignments.

* See paragraph 11.6.4.1 for detailed electrical characteristics of these differential signals.

Table 11.6.3-1b. ST12400WC single ended, 80 pin cable pin assignments (Non-shielded connector)

Signal	Pin Number	Signal	Pin Number
+12 V	1	12 V GND	41
+12 V	2	12 V GND	42
+12 V	3	12 V GND	43
+12 V	4	12 V GND	44
NC	5	NC	45
NC	6	NC	46
-D11	7	GND	47
-D10	8	GND	48
-D9	9	GND	49
-D8	10	GND	50
-IO	11	GND	51
-REQ	12	GND	52
-CO	13	GND	53
-SEL	14	GND	54
-MSG	15	GND	55
-RST	16	GND	56
-ACK	17	GND	57
-BSY	18	GND	58
-ATN	19	GND	59
-DBP	20	GND	60
-DB7	21	GND	61
-DB6	22	GND	62
-DB5	23	GND	63
-DB4	24	GND	64
-DB3	25	GND	65
-DB2	26	GND	66
-DB1	27	GND	67
-DB0	28	GND	68
-DP1	29	GND	69
-D15	30	GND	70
-D14	31	GND	71
-D13	32	GND	72
-D12	33	GND	73
+5 V	34	5 V GND	74
+5 V	35	5 V GND	75
+5 V	36	5 V GND	76
SYNC	[1] 37	LEDC	[2] 77
MTRON	[3] 38	DLYDST	[4] 78
SCSIAO	[5] 39	SCSIA1	[5] 79
SCSIA2	[5] 40	SCSIA3	[5] 80

Notes: Singals [1] thru [5] are used in place of installing jumpers and cables on option select connectors J2, J5 and J6. See also notes following Figure 10.1-1.

- [1] Synchronous spindle synchronizing signal, generated by either host or drive.
- [2] Front panel LED signal; indicates drive activity for host front panel hard drive activity indicator.
- [3] Asserted by host to enable Motor Start option (enables starting motor via SCSI bus command).
- [4] Asserted by host to enable Delayed Motor Start option (motor starts at power on or after a delay of 12 seconds times drive ID). This and [3] above are mutually exclusive options.
- [5] Binary code on A3, A2, A1 and A0 asserted by host to set-up SCSI bus ID in drive.

Note. The minus sign next to the signals indicates asserted state is the low voltage of the two levels used for logic signals.

Table 11.6.3-1c. ST12400W single ended cable pin assignments (nonshielded connector)

Signal Name*	Connector Contact Number	Cable Conductor Number	Connector Contact Number	Signal Name	
Ground	1	1	2	35	-DB(12)
Ground	2	3	4	36	-DB(13)
Ground	3	5	6	37	-DB(14)
Ground	4	7	8	38	-DB(15)
Ground	5	9	10	39	-DB(P1)
Ground	6	11	12	40	-DB(0)
Ground	7	13	14	41	-DB(1)
Ground	8	15	16	42	-DB(2)
Ground	9	17	18	43	-DB(3)
Ground	10	19	20	44	-DB(4)
Ground	11	21	22	45	-DB(5)
Ground	12	23	24	46	-DB(6)
Ground	13	25	26	47	-DB(7)
Ground	14	27	28	48	-DB(P)
Ground	15	29	30	49	Ground
Ground	16	31	32	50	Ground
TermPwr	17	33	34	51	TermPwr
TermPwr	18	35	36	52	TermPwr
Reserved	19	37	38	53	Reserved
Ground	20	39	40	54	Ground
Ground	21	41	42	55	-ATN
Ground	22	43	44	56	Ground
Ground	23	45	46	57	-BSY
Ground	24	47	48	58	-ACK
Ground	25	49	50	59	-RST
Ground	26	51	52	60	-MSG
Ground	27	53	54	61	-SEL
Ground	28	55	56	62	-C/D
Ground	29	57	58	63	-REQ
Ground	30	59	60	64	-I/O
Ground	31	61	62	65	-DB(8)
Ground	32	63	64	66	-DB(9)
Ground	33	65	66	67	-DB(10)
Ground	34	67	68	68	-DB(11)

- **Notes.**
1. See paragraph 11.6.4.1 for detailed electrical characteristics of these signals.
 2. The conductor number refers to the conductor position when using 0.025-inch centerline flat ribbon cable. Other cables types may be used to implement equivalent contact assignments.

11.6.4 Electrical description

The ST12400W/WC models use single ended interface signals. These signals must be terminated with 110 ohm active termination circuits at each end of the total cable. ST12400WC drives have no provisions for terminators on the PCB. On model ST12400WC some method of external termination must be provided by the user, systems integrator or the host equipment manufacturer. On ST12400W drives terminator power can be supplied from the drive to the I/O connector by the drive by properly positioning the **TP** jumper plug and the J2 option select header. See Figure 10.1-1a. Single Ended circuits use open collector or three state drivers. See Figure 11.6.4-1a and 11.6-1b.

The model ST12400WD uses differential interface signals and each of these must be terminated at each end of the total cable with 330 ohms to +5 V and 330 ohms to ground with 150 ohms between each differential pair. All I/O circuits are open collector, three state drivers. See Figure 11.6.4-1b for circuit drawing. ST12400WD drives have no provisions for adding terminators on the PCB. Some method of external termination must be provided (where needed) by the user, systems integrator or host equipment manufacturer. The ST12400WD model drive can furnish terminator power to the SCSI I/O cable by properly positioning jumper plug **TP**. See Figure 10.1-1a.

11.6.4.1 Single ended drivers/receivers

Typical single ended driver and receiver circuits for the ST12400W/WC is shown in Figure 11.6.4-1a. Terminator circuits shown (Note [1]) are to be enabled ("W" model) or installed externally only when the disc drive is first or last in the daisychain.

Transmitter characteristics

Single ended drives use an ANSI SCSI compatible open collector single ended driver. This driver is capable of sinking a current of 48 mA with a low level output voltage of 0.4 volt.

Receiver characteristics

Single ended drives use an ANSI SCSI single ended receiver with hysteresis gate or equivalent as a line receiver.

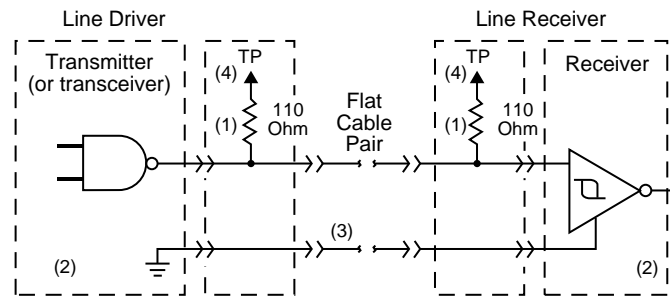

- [1] Part of active terminator circuits. Termination is required when the drive is first or last in the daisychain. Terminators and a place to plug them must be provided by the user, systems integrator or systems designer.
- [2] ANSI SCSI compatible circuits
- [3] Total interface cable length should not exceed that specified in paragraph 11.6.2.2.1.
- [4] Arrangements for connecting terminator power to the terminators must be made by the systems designer. The ST12400WC drive cannot furnish terminator power because the 80 pin I/O connector has no pins devoted to terminator power.
- [5] Interface signals levels and logical sense at the drive I/O connector are defined as follows:

Logic Level	Driver Output	Receiver Input
Negated (0)	$\geq 2.5 \text{ V}; \leq 5.25 \text{ V}$	$\geq 2.0 \text{ V}; \leq 5.25 \text{ V}$
Asserted (1)	$\leq 0.4 \text{ V}; \geq 0.0 \text{ V}$	$\leq 0.8 \text{ V}; \geq 0.0 \text{ V}$

The difference in the voltages between input and output signals is due to the losses in the cable.

Figure 11.6.4-1a. Typical single ended transmitters and receivers

11.6.4.2 Differential drivers/receivers

Typical differential driver and receiver circuits used by the model ST12400WD are shown in Figure 11.6.4-1. The drive has no provisions for terminator circuits on the drives.

Differential signals

All differential interface signals consist of two lines denoted +SIGNAL and -SIGNAL. A signal is true when +SIGNAL is more positive than -SIGNAL, and a signal is false when -SIGNAL is more positive than +SIGNAL. All assigned signals shall be terminated at each end of the cable as shown in Figure 11.6.4-1. Drive user, systems integrator or OEM manufacturer must provide some external means of termination. Terminator power can be supplied by the drive to the I/O cable by properly positioning a jumper plug. See Figure 10.1-1.

Output characteristics

Each signal driven by differential interface drives shall have the following output characteristics when measured at the disc drive SCSI connector:

Low-level output voltage* = 2.0 V maximum at Low-level output current = 55 milliamps.

High-level output voltage* = 3.0 V minimum at High-level output current = -55 milliamps

Differential voltage = 1.0 V minimum with common-mode voltage ranges from -7 V dc to +12 V dc.

* These voltages shall be measured between the output terminal and the SCSI device's logic ground reference.

The output characteristics shall additionally conform to EIA RS-485-1983.

Input characteristics

Each signal received by differential interface drives shall have the following input characteristics when measured at the disc drive SCSI connector:

Input current on either input = +2.0 milliamps maximum (includes both receivers and passive drivers).

This requirement shall be met with the input voltage varying between -7 V dc and +12 V dc, with power on or off, and with the hysteresis equaling 35 mv, minimum.

The input characteristics shall additionally conform to EIA RS-485-1983.

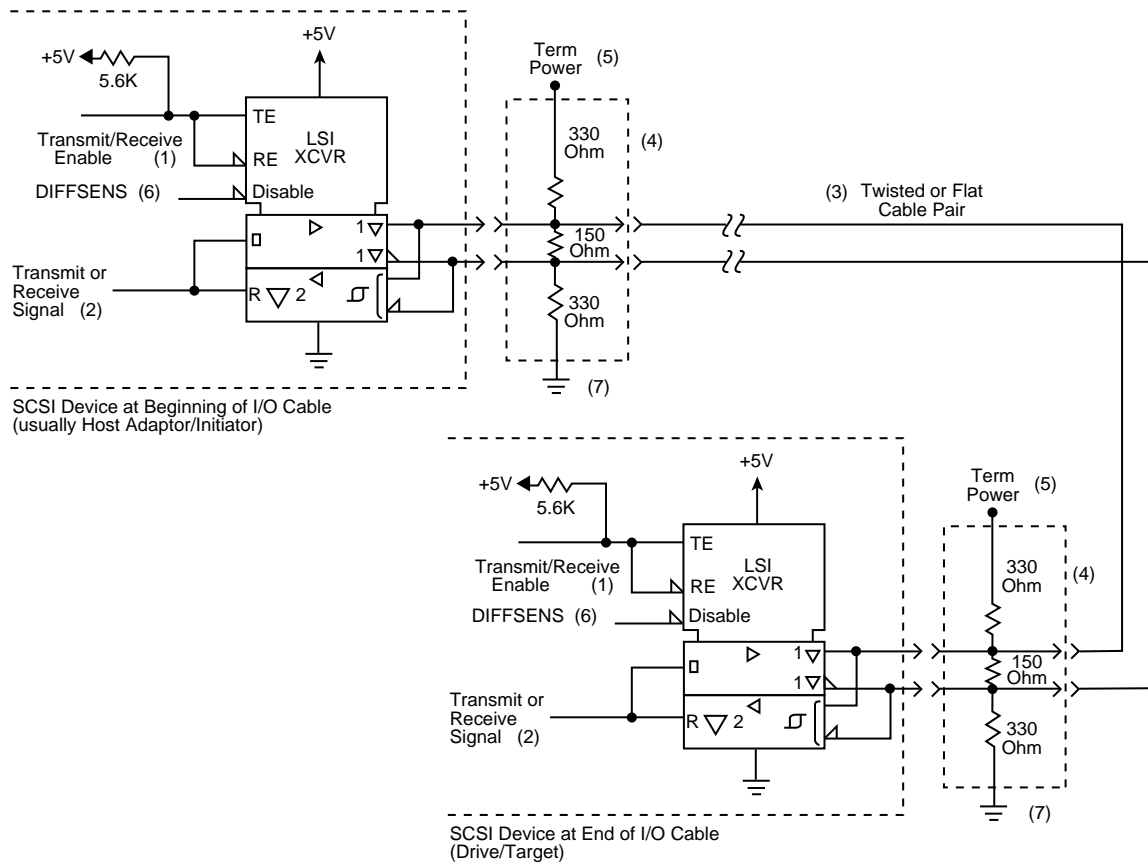

Notes.

- [1] Positive Logic Enables Transmitter (+5 V = Asserted)
Negative Logic Enables Receivers (0 V = Asserted)
- [2] Negative Logic Signal (0 V = Asserted)
- [3] Total interface cable length should not exceed value given in section 11.6.2.1 from first SCSI device at beginning to end of daisychain. See section 11.6.4.1 for signal characteristics.
- [4] I/O Line terminators. If SCSI device is a Seagate disc drive, terminators and a place to plug them in must be provided external to the drive by user, systems integrator or systems designer where needed. The drive has no terminators and there are no provisions on the drive for terminator installation.
- [5] Arrangements for connecting terminator power to the terminators must be made by the systems designer. As a help, drive +5 V power is made available on model ST12400WD on SCSI bus pins 17, 18, 51 and 52 for powering external terminators if the drive option select header jumper TP (Figure 10.1-1a) is installed in the proper position.
- [6] SCSI I/O line (pin 16) disables I/O circuits if single-ended cable is plugged in.
- [7] SCSI I/O cable ground. See Table 11.6.3-1b.

Figure 11.6.4-1b. Typical differential I/O line transmitter/receiver and terminators

11.6.4.2 Terminator requirements

Drive I/O termination is not provided internally on ST12400WD or ST12400WC drives. Terminator circuits, must be provided in some manner *external* to the ST12400WD/WC drives by the user, systems integrator or OEM manufacturer. It is highly recommended that ANSI SCSI-2 Standard's Alternative 2 termination (active termination) be used for single-ended ST12400W and ST12400WC applications, especially if the bus will be operated at transfer rates above 5 Mbytes/sec. The ST12400W provides on-board active termination that can be disabled by removal of the enable jumper **TE** (see Figure 10.1-1). Power for the external terminators may be taken from the drive (see paragraph 11.6.4.3) by installing a jumper plug on one of the J2-**TP** (see Figure 10.1-1a). If the **TP** jumper is not installed terminator power must be supplied by some other source. All single initiator/single target (nondaisychain) applications require that the Initiator and disc drive be terminated. Daisychain applications require that only the units at each end of the daisychain be terminated. All other peripherals on the chain should not be terminated. (See Figure 11.6.3-1).

Note. Where terminators are not required, remove external terminator modules or disable terminators on the model ST12400W by removing the TE jumper from header J2 (see Figure 10.1-1a). Removal of terminator power source selection jumper **TP** does not disconnect the terminators from the circuit.

Note. ACTIVE TERMINATORS ARE HIGHLY RECOMMENDED FOR USE IN THE DAISYCHAIN AS DESCRIBED ABOVE. ACTIVE AND PASSIVE TERMINATORS SHOULD NOT BE MIXED ON THE SAME SCSI BUS.

11.6.4.3 Terminator power

The model ST12400W/WD drives may be configured to provide terminator power via pins 17, 18, 51 and 52 of the SCSI Bus, to supply power to the SCSI bus. See Figure 11.6.3-1 and 10.1-1. The drive can provide power both to external terminators at the drive end and to the SCSI Bus terminator power lines to provide power for terminators at the other end of the I/O cable.

SCSI devices providing terminator power (TERMPWR) shall have the following characteristics:

V TERM = 4.50 V to 5.25 V
800 mA min source drive capability
1.0 A maximum

The model ST12400WC drive cannot furnish terminator power, because no pins in the 80 pin I/O connector are devoted to terminator power.

11.7 Disc drive SCSI timing

Table 11.7-1. Disc drive SCSI timing

Description	Waveform Symbol [1]	Waveform Table [1]	Typical	Max
Target Select Time (no Arbitration)	T00	N/A	<1 μ s	<250 μ s
Target Select Time (with Arbitration)	T01	4.5-1,2	2.34 μ s	2.44 μ s
Target Select to Command	T02	4.5-1	3.82 μ s	3.84 μ s
Target Select to MSG Out	T03	4.5-2	1.62 μ s	1.66 μ s
Identify MSG to Command	T04	4.5-3	3.56 μ s	3.64 μ s
Command to Status	T05	4.5-5	Command Dependent	
Command to Data (para. In)	T06	4.5-9	Command Dependent	
Command to Data (para. Out)	T07	4.5-10	Command Dependent	
Command to Data (Write to Data Buffer)	T08	4.5-10	Command Dependent	
Command to Disconnect MSG	T09	4.5-6	Command Dependent	
Disconnect MSG to Bus Free	T10	4.5-6,14	0.68 μ s	0.78 μ s
Disconnect to Arbitration (for Reselect)	T11	4.5-6	Command Dependent	
This measures disconnected CMD overhead.				
Target win Arbitration (for Reselect)	T12	4.5-7		3.0 μ s
Arbitration to Reselect	T13	4.5-7		1.82 μ s
Reselect to Identify MSG In	T14	4.5-7		1.52 μ s
Reselect Identify MSG to Status	T15	4.5-8	Command Dependent	
Reselect Identify MSG to Data (media)	T16	4.5-11	Command Dependent	
Data to Status	T17	4.5-15	Command Dependent	
Status to Command Complete MSG	T18	4.5-5,8,15		1.04 μ s
Command Complete MSG to Bus Free	T19	4.5-5,8,15		0.80 μ s
Data to Save Data Pointer MSG	T20	4.5-14		5.00 μ s
Save Data Pointer MSG to Disconnect MSG	T21	4.5-14		0.85 μ s
Command Byte Transfer	T22	4.5-4		0.06 μ s
Next Command Byte Access		4.5-4		
Next CDB Byte Access (Byte 2 of 6)	T23.6.2	4.5-4	0.54 μ s	0.64 μ s
Next CDB Byte Access (Byte 3 of 6)	T23.6.3	4.5-4	0.11 μ s	0.14 μ s
Next CDB Byte Access (Byte 4 of 6)	T23.6.4	4.5-4	0.12 μ s	0.14 μ s
Next CDB Byte Access (Byte 5 of 6)	T23.6.5	4.5-4	0.13 μ s	0.14 μ s
Next CDB Byte Access (Byte 6 of 6)	T23.6.6	4.5-4	0.11 μ s	0.14 μ s

continued from previous page

Description	Waveform Symbol [1]	Waveform Table [1]	Typical	Max.
<u>Asynchronous Data Transfer Characteristics: (continued)</u>				
Next CDB Byte Access (Byte 2 of 10)	T23.10.2	4.5-4	0.51 μ s	0.60 μ s
Next CDB Byte Access (Byte 3 of 10)	T23.10.3	4.5-4	0.13 μ s	0.14 μ s
Next CDB Byte Access (Byte 4 of 10)	T23.10.4	4.5-4	0.11 μ s	0.14 μ s
Next CDB Byte Access (Byte 5 of 10)	T23.10.5	4.5-4	0.12 μ s	0.14 μ s
Next CDB Byte Access (Byte 6 of 10)	T23.10.6	4.5-4	0.12 μ s	0.14 μ s
Next CDB Byte Access (Byte 7 of 10)	T23.10.7	4.5-4	0.11 μ s	0.14 μ s
Next CDB Byte Access (Byte 8 of 10)	T23.10.8	4.5-4	0.12 μ s	0.14 μ s
Next CDB Byte Access (Byte 9 of 10)	T23.10.9	4.5-4	0.11 μ s	0.14 μ s
Next CDB Byte Access (Byte 10 of 10)	T23.10.10	4.5-4	0.13 μ s	0.14 μ s
Data In Byte Transfer (parameter)	T24	4.5-12		0.06 μ s
Data Out Byte Transfer (parameter)	T25	4.5-13		0.06 μ s
Next Data In Byte Access (parameter)	T26	4.5-12	0.10 μ s	0.14 μ s
Next Data Out Byte Access (parameter)	T27	4.5-13	0.11 μ s	0.14 μ s
Data In Byte Transfer (media) [2]	T28	4.5-12	0.04 μ s	0.06 μ s
Data Out Byte Transfer (media) [2]	T29	4.5-13	0.04 μ s	0.06 μ s
Next Data In Byte access (media) [2]	T30	4.5-12	0.10 μ s	0.14 μ s
Next Data Out Byte access (media) [2]	T31	4.5-13	0.10 μ s	0.14 μ s
MSG IN Byte Transfer	T32	4.5-5,7 4.5-8,14,15		0.06 μ s
MSG OUT Byte Transfer	T33	4.5-2		0.06 μ s
STATUS Byte Transfer	T34	4.5-5,8 4.5-15		0.06 μ s
<u>Synchronous Data Transfer Characteristics:</u>				
Request Signal Transfer Period [3]	-	-	various	800 ns

Notes.

- [1] See SCSI-2 Interface Manual P/N 77738479 (called Volume II), section 4.5
 [2] Maximum SCSI asynchronous interface transfer rate is given in section 5.3.
 [3] Synchronous Transfer Period is determined by negotiations between an Initiator and a Drive. The Drive is capable of setting periods as given in section 11.5. See also sections 3.1.5.2 and 3.5.3.2 of the SCSI-2 Interface Product Manual (P/N 77738479) for a description of synchronous data transfer operation.

General timing diagrams for SCSI interface operation are shown in the SCSI-2 Interface Product Manual P/N 77738479, Section 4.5. The specific timing values that apply to this drive are listed in Table 11.7-1.

12.0 Options

All options are incorporated or packaged at the manufacturing facility.

12.1 Front panel

The normal front panel available is black plastic. Other panel colors may be special ordered. Each panel has a single rectangular green LED indicator lens which, when glowing, indicates the drive is selected.

12.2 Single unit shipping pack

The drive is normally shipped in bulk packaging to provide maximum protection against transit damage. Units shipped individually require additional protection as provided by the single unit shipping pack. Users planning single unit distribution should specify this option.

13.0 Accessories

All accessories are designed for implementation by the customer.

13.1 Front panel kit

Same as 12.1 but includes all mounting hardware to support field installation.

13.2 Installation manual

This manual (P/N 77767465) provides basic information on the care and handling of Winchester disc peripherals in general. Some information needed when installing the drive is included to assist individuals not familiar with the product. It also includes basic information to assist in obtaining service for the drive.

14.0 Seagate Technical Support services

Seagate Technology provides technical support literature and diagnostic utilities to Authorized Distributors. Please contact your dealer for technical support and installation troubleshooting. Product Technical Support is available for all Seagate products by calling the SeaFAX, SeaFone, SeaTDD or SeaBOARD services. These are toll calls.

SeaFAX: United States 408/438-2620

England 44-62-847-7080

You can use a Touch-Tone telephone to access Seagate's automated FAX delivery system and select technical support information by return FAX. This service is available 24 hours a day, 7 days a week.

Seagate Technical Support FAX: 408/438-8137

You can FAX specific questions or comments to Seagate technical support specialists 24 hours daily. Responses are FAXed between 8:00 a.m. and 5:00 p.m. (Pacific time), Monday through Friday.

SeaFone: 408/438-8222

The enhanced phone system provides recorded technical information on selected Seagate products while you are on hold. Technical support specialists are available to answer questions from 8:00 AM to 5:00 PM PST, Monday through Friday. Recordings are accessible 24 hours a day, 7 days a week.

SeaTDD: 408/438-5382

TDD is a Telecommunication Device for the Deaf where two people can communicate using a keyboard that is connected to the phone line. A TDD device is required to access this service. This service is available from 8:00 AM to 5:00 PM PST, Monday through Friday.

SeaBOARD:

The Seagate Technical Support Bulletin Board System (BBS) is available 24 hours a day, 7 days a week. A modem is required to access this service. (300–9600 baud, 8-N-1). This is a toll call.

With this service you can access:

- Specifications and jumper configurations for all Seagate products.
- Reprints of Seagate documentation.
- A directory of information and helpful utilities that you can download to your own computer.

BBS Location	Modem Number
USA, Mexico, Latin America	408/438-8771
England	44-62-847-8011
France	33-1-40-67-1034
Germany	49-89-140-9331
Singapore	65-292-6973
Australia	61-2-756-2359
Korea	82-2-556-7294
Thailand	662-531-8111

CompuServe: Online technical support for Seagate Products is available on CompuServe. Type "Go Seagate" to access our technical support forum.

Seagate Peripheral Family

Listed below are some of the SEAGATE Peripheral family members. For specific information on each member, refer to the appropriate documents.

Model Name	Model Number	Product Manual	Interface	Unformatted Capacity (MB)
HAWK 1 Family				
ST11200	ST11200N/ND/NC	77738476(I)	SCSI-2	1248*
	ST1980N/ND/NC	77738476(I)	SCSI-2	1021*
	ST1950N	77738476(I)	SCSI-2	953
	ST1830N	77738476(I)	SCSI-2	834
HAWK 2 Family				
ST12400	ST12400N/ND/NC	77767450(I)	SCSI-2	2537*
	ST11900N/ND/NC	77767450(I)	SCSI-2	2003*
ST12400 Wide	ST12400W/WD/WC	77767457(I)	SCSI-2	2537*
HAWK 1LP Family				
ST31200	ST31200N/ND/NC	77767452(I)	SCSI-2	1258.8*
	ST3620N/NC	77767452(I)	SCSI-2	651.8*
ST31200 Wide	ST31200W/WD/WC	77767461(I)	SCSI-2	1258.8*
	ST3620W	77767461(I)	SCSI-2	
HAWK 2LP Family				
ST32430	ST32430N/ND	77767471(I)	SCSI-2	2.59 GB*
	ST31230N/ND	77767471(I)	SCSI-2	1.28 GB*
ST32430 Wide	ST32430W/WD/WC/DC	77767480(I)	SCSI-2	2.59 GB*
	ST31230W/WD/WC/DC	77767480(I)	SCSI-2	1.28 GB*
HAWK 2XL Family				
ST32151	ST32151N	77767489(I)	SCSI-2	
	ST31051N	77767489(I)	SCSI-2	
HAWK 4 Family				
ST15230	ST15230N/ND	77767472(I)	SCSI-2	5170 MB*
ST15230 Wide	ST15230W/WD/WC/DC	77767479(I)	SCSI-2	5170 MB*
SCSI INTERFACE				
SCSI Interface Manual, Vol. 2		77765466 (II)**	SCSI-2	N/A**
SCSI Interface Manual; Vol. 2; Ver. 2		77738479 (II)**	SCSI-2/SCSI-3	N/A**

* Product Manual covers both Single-Ended and Differential Interfaces.

** Interface Manual for several different Product Manuals (Volume 2 of 2 Volume set).

continued from previous page

Model Name	Model Number	Product Manual	Interface	Unformatted CapacityC(MB)
ST3600	ST3500N	77738477(I)	SCSI-2	502
	ST3600N	77738477(I)	SCSI-2	617
	ST3610N/ND/NC	77738495(I)	SCSI-2	635*
	ST3600A	77738485	AT (IDE)	617
ST1480 Family	ST1400N	77765458(I)	SCSI-2	383
	ST1401N	77765458(I)	SCSI-2	390
	ST1480N	77765458(I)	SCSI-2	492
	ST1481N	77765458(I)	SCSI-2	492
	ST1581N	77738471(I)	SCSI-2	610
	ST1480A	77738463	AT (IDE)	490
	ST1400A	77738463	AT (IDE)	381
	ST1401A	77738463	AT (IDE)	395
WREN 5 Family	ST4442E	77765300	ESDI	442 (15 Hd, 1412 Cyl)
	ST4383E	77765300	ESDI	383 (13 Hd, 1412 Cyl)
	ST4384E	77765300	ESDI	383 (15 Hd, 1224 Cyl)
	ST4702N	77765336	SCSI	702
	ST4385ND			
	ST4702ND	77765366	SCSI	385, 702 (Dif. I/O)*
ST4385N	77765378	SCSI	385 (15 Hd, 791 Cyl)	
WREN 6 Family	ST4766N/ND	77765353	SCSI	766 (Dif. I/O)*
	ST4766E	77765358	ESDI	766, 383
WREN 6 HH Family	ST2383N/502N	77765414	SCSI-1	383, 502
	ST2274A/383A	77765393	AT (IDE)	274, 383
	ST2182E/383E	77765369	ESDI	182, 383
WREN 7 Family	ST41200N/ND	77765417	SCSI	1200*
	ST41200N/ND	77765374	SCSI-2	1200*
WREN 8 Family	ST41650N	77765470 (I)	SCSI-2	1650
	ST41651N/ND	77738474 (I)	FAST SCSI-2	1650
WREN 9 Family	ST42100N	77738475 (I)	FAST SCSI-2	2200
WREN RNR-2 Family	ST4767N	77765445 (I)	SCSI-2	767 (Fast Access)
	ST4767E/769E	77765457	ESDI	767

* Product Manual covers both Single-Ended and Differential Interfaces.C



Seagate Technology, Inc.
920 Disc Drive, Scotts Valley, California 95066-4544, USA

Publication Number: 77767457, Rev. C (03/95)

Printed in USA